

# Vixen<sup>®</sup>

## Instruction Manual for altazimuth mount APZ



## PREFACE

Thank you for your purchase of a Vixen APZ altazimuth mount or a Vixen product from the APZ series of mount packages.

This instruction manual is prepared in common with the APZ mount series. You may occasionally find descriptions in the text not relevant to your model. The manual explains usage of the APZ mount with manual slow motion control modules mostly. Please be sure to read the instructions throughout to make you use the product right and safety.

This equipment has been tested and found to comply with the limits for a Class B digital device, pursuant of Part 15 of the FCC rules.

## SAFETY PRECAUTIONS

This instruction manual will assist you in the safe and effective use of the APZ Mount. Before using the mount, be sure to carefully read the safety precautions described below.

Legend	
⚠ Warning	If misused, it can cause you a serious injury or death.
⚠ Caution	Misuse can cause injury or damage to you or other property.
🔍 Important	You must complete all of the steps in this manual.
🕒 Direction	You must completely execute the instructions in this manual.

### ⚠ WARNING

- 🔍 Never look directly at the sun with your naked eyes or through your telescope and finder scope. Permanent and irreversible eye damage may result.
- 🔍 Do not leave the optical tube uncapped in the daytime. Sunlight passing through the telescope or finder scope may cause a fire.
- 🔍 Do not use the product in a wet environment. This could damage the mount, result in electrical shock or a fire.
- 🔍 Do not attempt to disassemble or alter any part of the equipment that is not expressly described in this manual. This could damage the mount, result in electrical shock, a fire or lead to an injury.
- 🕒 Keep small caps, plastic bags or plastic packaging materials away from children. These may cause choking or suffocation.
- 🕒 Stop operating the product immediately and unplug the power cord if it emits smoke or a strange smell. This could result in fire or electrical shock. Make sure to be safe and consult your local Vixen dealer or distributor in your country.
- 🕒 Do not allow liquids or foreign objects to enter the product. Unplug the power cord or switch the power off. This could result in fire or electrical shock.
- 🕒 Do not damage, alter or place heavy item on the power cord. This could result in fire or electrical shock.
- 🕒 The product includes heavy items such as the counterweight and the mount body. Be sure to handle these units carefully. Be careful not to drop the unit when handling. This may cause damage or lead to injury.
- 🕒 Be sure to ventilate air while cleaning with volatile cleaner or spray ca cleaner to avoid poisoning.
- 🕒 Do not use the volatile cleaner or spray can cleaner in the vicinity to fire.

### 🔍 CAUTION

- 🔍 Do not operate the product with wet hands. Plugging in and out the power cord, electricity connectors and operating the electronic parts with wet hands may cause damage to the equipment or resulting in electrical shock.
- 🔍 Do not use the product while travelling or walking, as injuries may arise from stumbling, falling or collision with objects.
- 🔍 Do not bundle the power cord and electricity wires during the operation. This may result in a short circuit and damage to the surroundings.
- 🕒 Handle the power cord and electricity connectors properly. Do not pull the power cord by force when disconnecting. This may damage the cord and connectors, resulting in fire or electrical shock.

## HANDLING AND STORAGE

- 🔍 Do not leave the product inside a car in bright sunshine, or in hot places. Keep any strong heat radiation sources away from the product.
- 🔍 When cleaning, do not use solvent such as paint thinners. It may cause deterioration.
- 🔍 Do not use the product in a wet environment. This may cause the product to malfunction or result in a fire or electrical shock.
- 🕒 For storage do not expose to direct sunlight and keep the product in a dry place.
- 🕒 Do not expose the product to rain, water drops, dirt or sand. Gently wipe the product with a damp cloth for cleaning.

<b>SAFETY PRECAUTIONS</b> .....	P 02
---------------------------------	------

<b>TABLE OF CONTENTS</b> .....	P 03
--------------------------------	------

## **BEFORE USE**

- Check the Package Contents ..... P 04
- Name of Each Component ..... P 05

## **PREPARATION**

- Assembling the APZ Mount ..... P 07
- Setting up the Tripod
- Attaching the Optical Tube Assembly ..... P 10
- Balancing the APZ Mount ..... P 11

## **BASIC OPERATION**

- Moving the APZ Mount ..... P 13

## **APPLICATION**

- Changing the Tension of the Friction Stop Motion -- P 13
- About Power Supply ..... P 14
- AP Mount Composition Chart ..... P 16
- Variations on the APZ Mount ..... P 17
- How to Change the Modules ..... P 18
- Replacing the Fuss ..... P 21

## **SPECIFICATIONS**

- Mount Specifications ..... P 28
- Dimensions of the APZ Mount, APP-TL 130 Tripod and Slow Motion Control Module

## BEFORE USE

### Check the Package Content

The APZ altazimuth mount contains the items listed below. Check if all the items are included.

Note: The contents of your APZ Mount package may differ when you purchase it as an AP Mount package complete with optical tube and tripod.

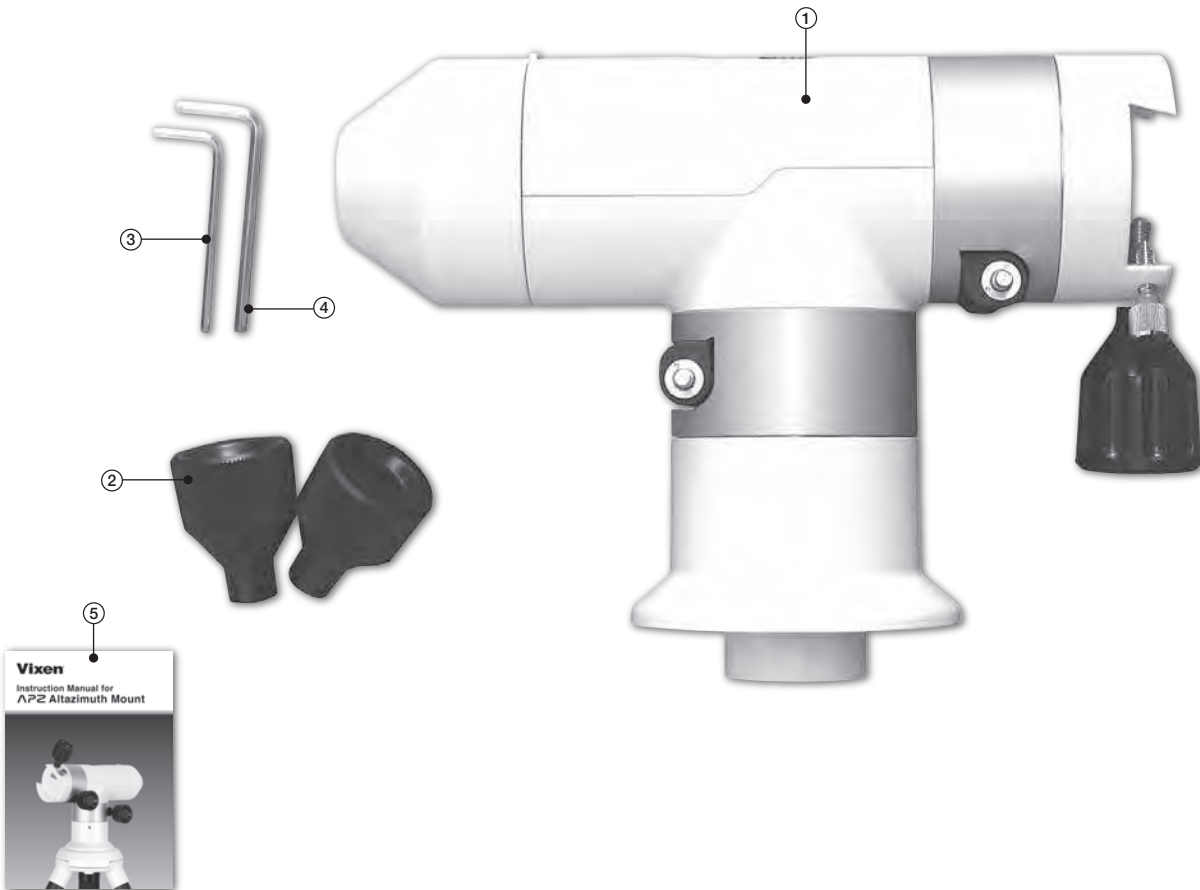

### Package Content

- ① APZ Altazimuth Mount
- ② Slow Motion Control Knobs
- ③ Allen Wrench of 3mm on a side
- ④ Allen Wrench of 4mm on a side
- ⑤ APZ Mount Instruction Manual (This book)

### Basics of the APZ Altazimuth Mount

- 1** The APZ Mount moves and stops with friction in the motion of up and down (vertical) and from side to side (horizontal) directions. Slew the telescope by hand to change the telescope's direction.
- 2** The APZ mount will achieve smooth movements if each of the rotational axes on the mount is balanced correctly. An unbalanced mount may cause vibration and can result in slipping of the friction stop mechanism. Make sure that your telescope is well balanced after your accessories have been installed.
- 3** Be careful not to bang any part of the mount against other objects. This could damage the gears and bearings.

**BEFORE USE**

**Name of Each Component**



**APZ Mount Package**

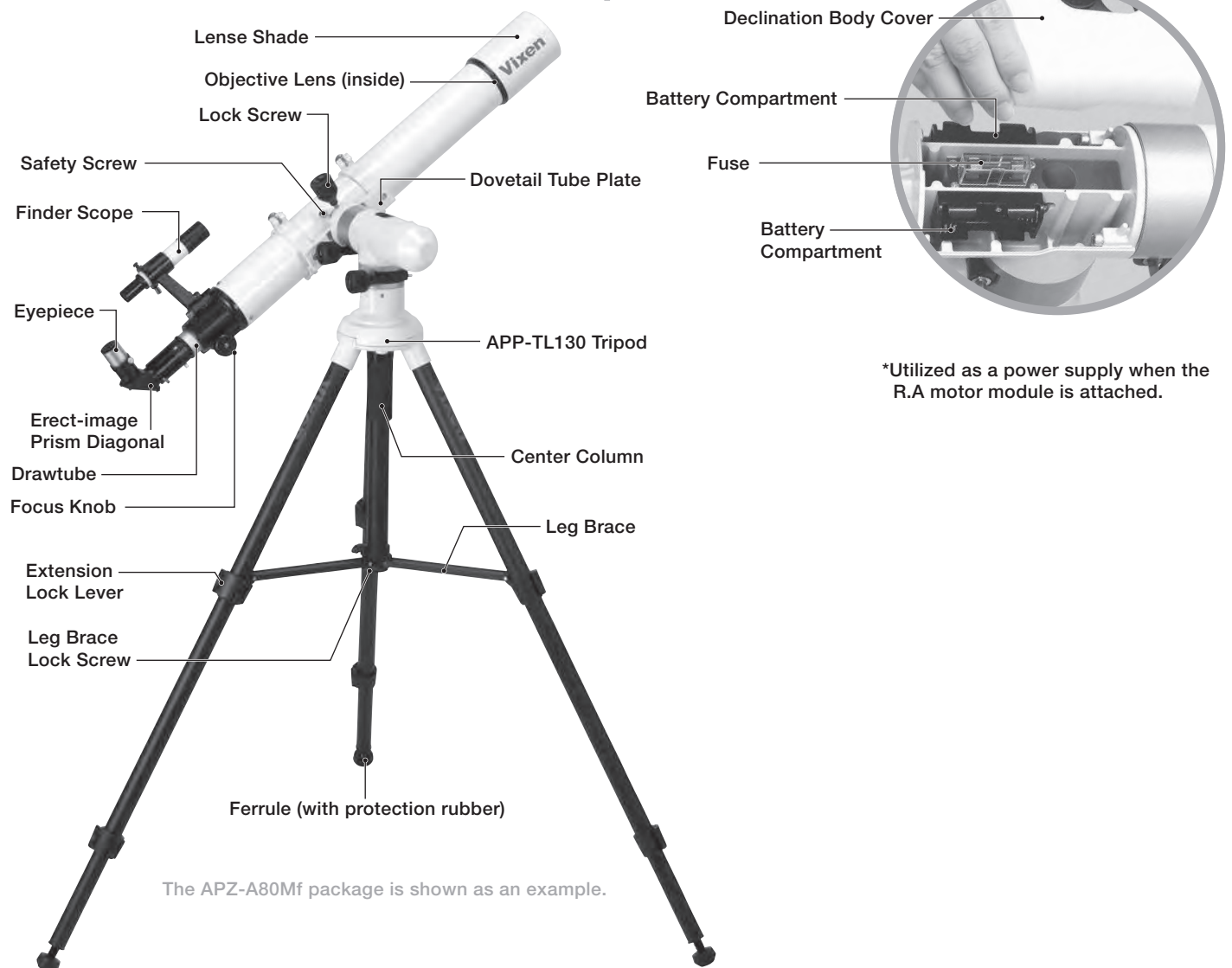

The APZ-A80Mf package is shown as an example.

## BEFORE USE

### Mount Head

The mounting block is designed to attach an optical tube with dovetail tube plate (or dovetail slide bar).

The optical tube is firmly fixed with both the lock screw with large grab knob and safety screw. This allows quick set up and removal of the optical tube.

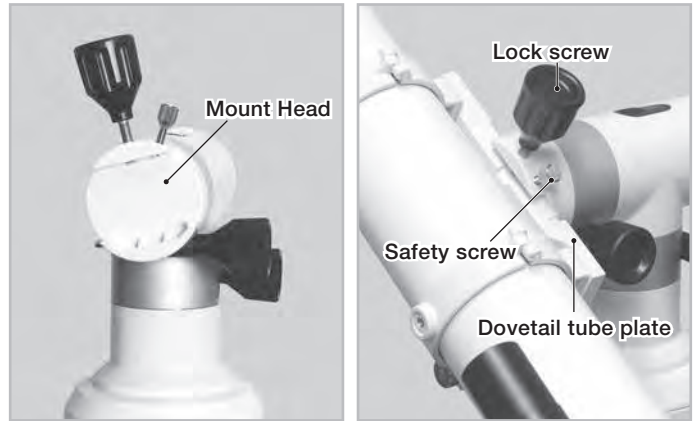

### AZ Counterweight

The optical tube mounted on the APZ mount has to be balanced with the AZ counterweight to make a motion of the APZ mount stable.

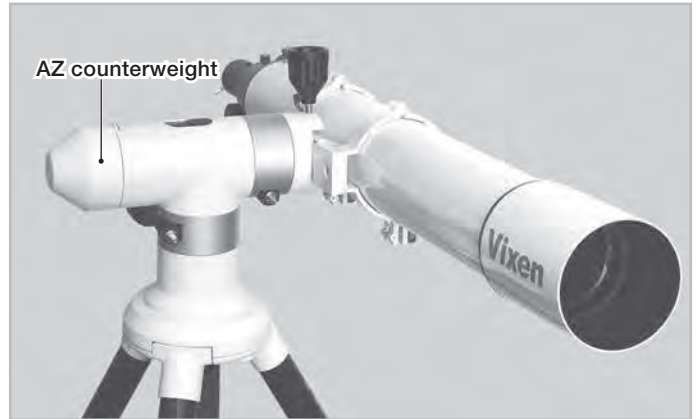

### Friction Stop Mechanism (Vertical and Horizontal Motions)

The APZ mount employs a friction stop mechanism which allows you to move the optical tube by hand in vertical (altitude) and horizontal (azimuth) directions so that you can quickly point it at your target celestial object. The optical tube moves as you guide it by hand and stops as you release.

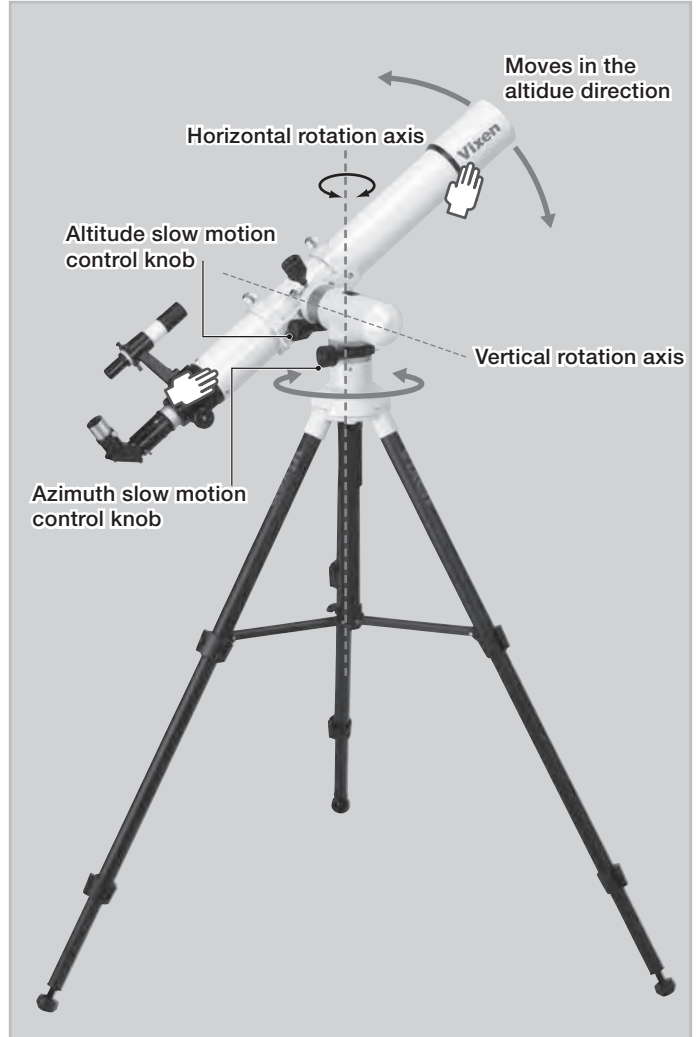

### Altitude and Azimuth Slow Motion Control Knobs

Fine adjustment of the optical tube in the altitude and azimuth directions is made manually by the slow motion control knobs when you use the telescope at high magnification.

## PREPARATION

### Assembling the APZ Mount

Refer to the instruction manual of your telescope and accessory together with this manual when you attach the optical tube assembly to the mount.

- ⚠ The unit includes heavy items. Take care not to drop them when assembling as it could seriously damage the equipment or lead to injury.
- ⚠ Take care not to pinch your finger with moveable pieces when setting up.

### Setting up the Tripod

**1** Place the tripod on a level ground to make the telescope stable during observation.

**2** Unfasten the extension lock lever on the tripod leg by pulling it out so that the tripod leg can be adjusted. To keep the better stability, extend the upper section of the tripod legs at first. Pull out the tripod legs until each leg extends to your necessary length.

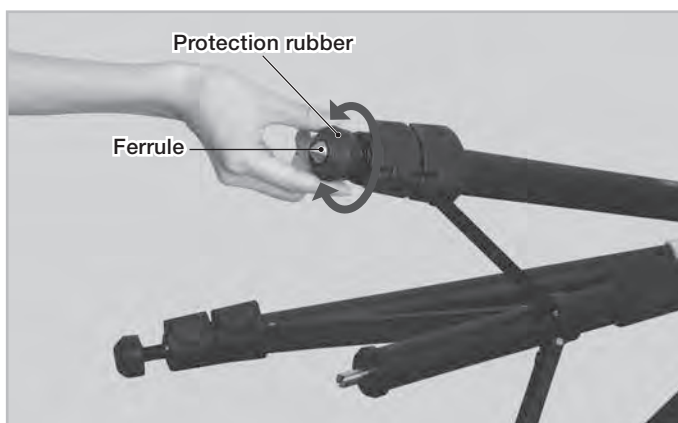

**3** Fasten the extension lock lever to hold the tripod leg securely in place.

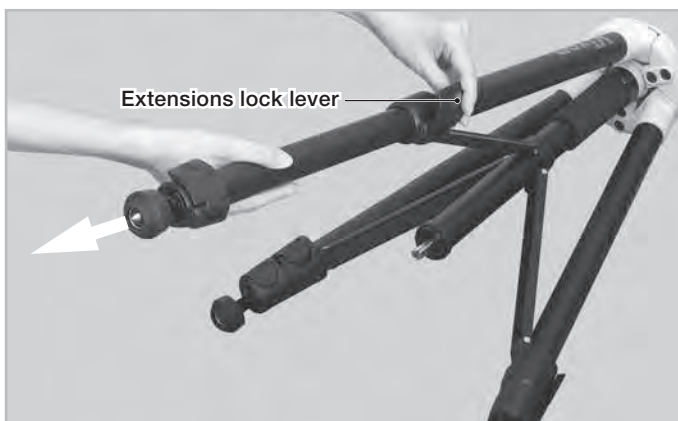

**4** Loosen the lock screw on the leg brace and pull the tripod legs apart until the leg brace is fully extended. Set up the top surface of the tripod head to be horizontal.

Note: Do not secure the leg brace in place at this stage as it hinders you from turning the center column.

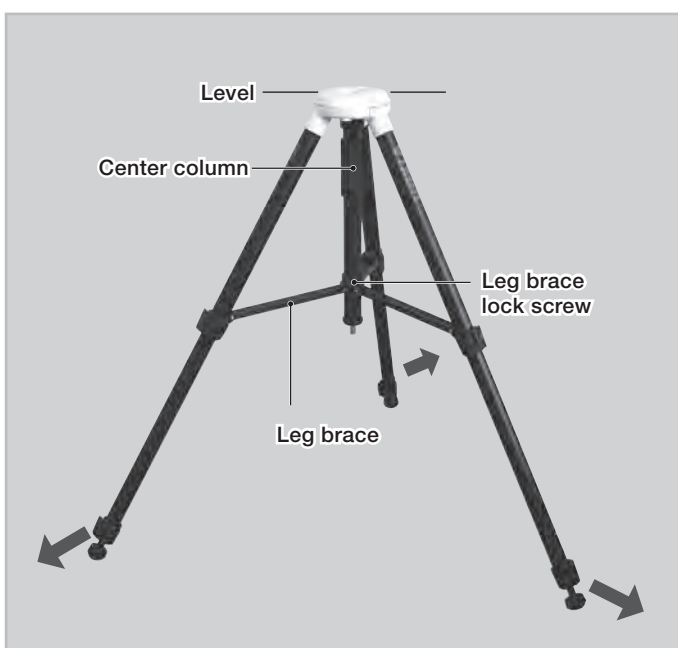

## PREPARATION

- 5** Place the APZ mount body over the tripod head. Attach the APZ mount body onto the tripod head so that the center projection on the bottom of the mount fits the center hollow on the tripod head.



- 6** With holding the mount body in one hand, raise the center column with the other hand so that the top of the column fits in the bottom of the mount. Turn the center column counterclockwise to screw the top of the column into the bottom of the mount until securely fastened.

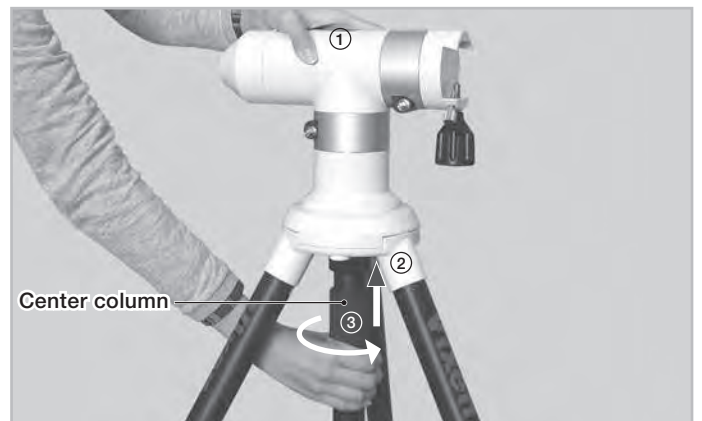

- 7** Push down the leg brace until it clicks as it enforces the stability of the tripod. Tighten the leg brace lock screw securely.

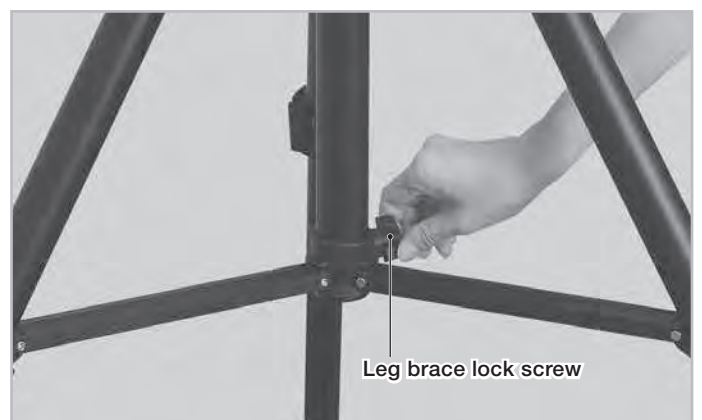
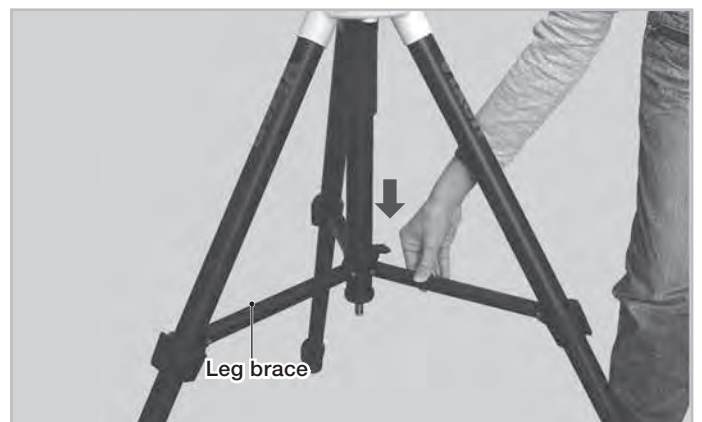

- 8** Repeat the above procedure when you change the height of the tripod.



## PREPARATION

- 9 Attach the Slow Motion Control Knobs. The slow motion control knob is attached onto the worm screw by push fit.

Place the manual slow motion control knob on the tip of the worm screw shaft so that the flat portion of the socket on the knob is joined with the flat portions of the tip on the shaft.

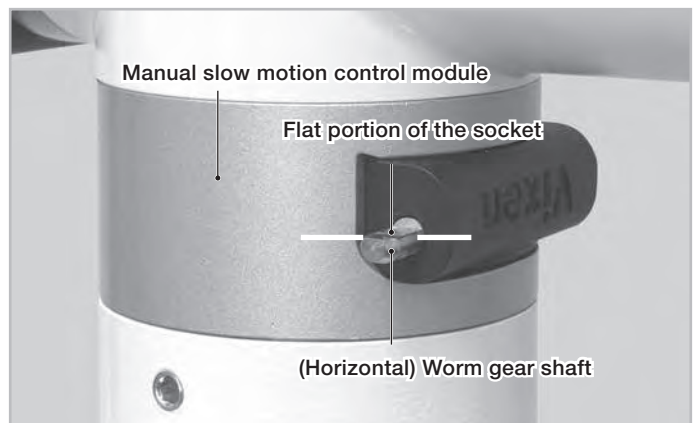
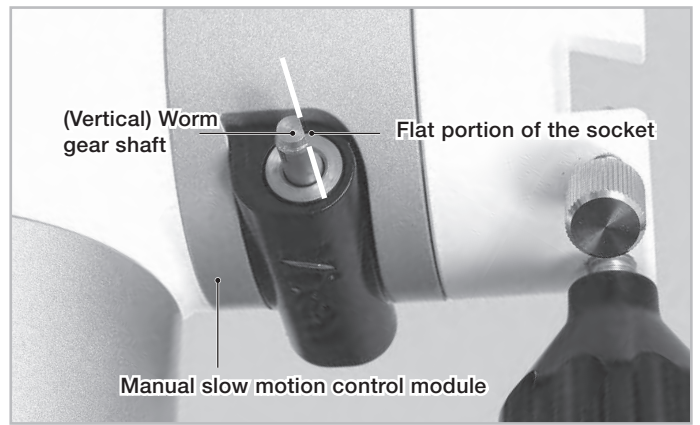
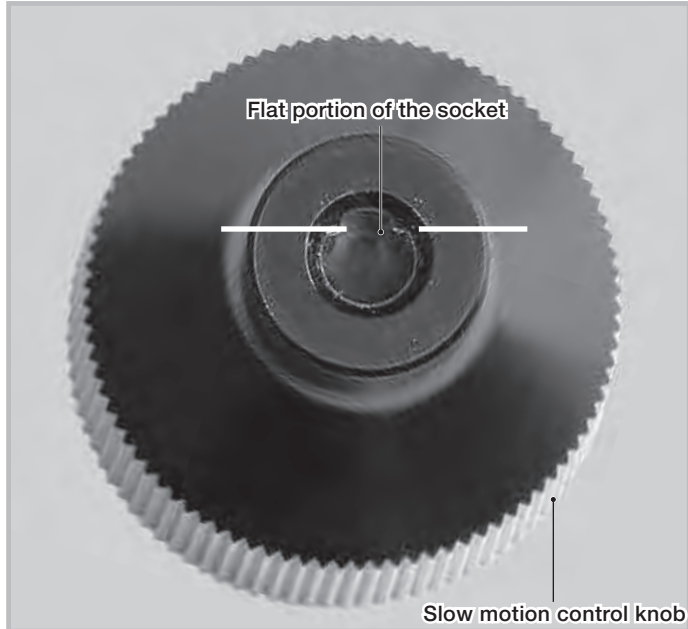

## PREPARATION

### Attaching the Optical Tube Assembly

The telescope tube attaches to the APZ mount via a dovetail tube plate.  
The permissible loading weight of the mount is 8kg (18 lbs).

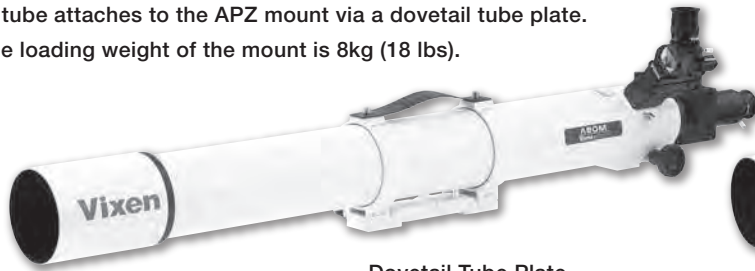

Dovetail Tube Plate



Dovetail Slide bar

⚠ Caution: Take care not to drop the telescope tube as it could result in serious damage.

- 1 Loosen both dovetail plate lock screw and the safety screw on the mount head fully so that you make space available for the dovetail tube plate.



- 2 Attach the telescope tube to the mount head so that the dovetail tube plate fits the sunken mount head neatly. Tighten the dovetail plate lock screw first onto the dovetail tube plate centering notch until snug. Then, tighten the safety screw securely.

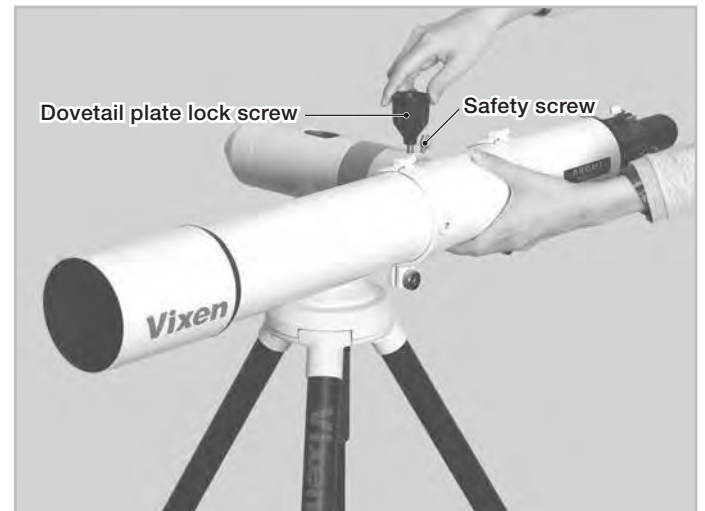

⚠ Caution: Make sure that the dovetail tube plate is flat against the mount head.

Make sure that the dovetail tube plate is flat against the mount head.  
Tightening the dovetail tube plate lock screw with a gap between these parts may cause the telescope tube to fall.

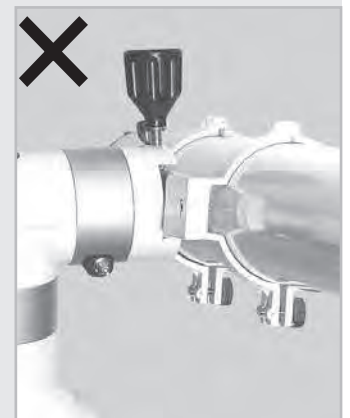

## PREPARATION

### Balancing the APZ Mount

The APZ mount employs the friction stop mechanism in the motion of both up and down and from side to side. It will tend to slip in the rotating motion if used in an unbalanced state. If the mount is in an unbalanced state, it will increase stress to the gears and this could result in unwanted vibration. It is necessary to adjust balance to bring the center of balance onto the rotational axis in the direction of altitude for a comfortable operation of the telescope.

### ⚠ Caution

Take care not to drop the optical tube assembly as it could seriously damage the equipment or lead to injury. Pay close attention to the security of the telescope tube and do not excessively loosen the lock knobs on the equipment.

#### Balancing the telescope tube with tube rings:

- 1 Level the telescope tube as shown in the figure. Release the telescope tube to see if it keeps the position as it stands. Readjust the balance if the telescope tube starts turning as you release it.

Loosen the lock knobs on the tube rings that hold the telescope tube and slide the telescope tube either forward or backward until it remains stationary.

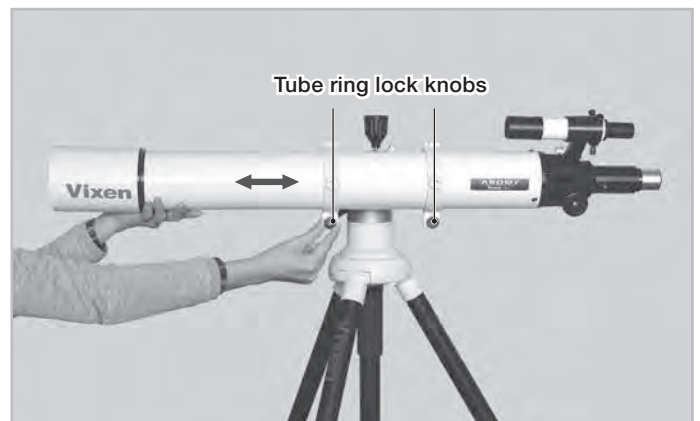
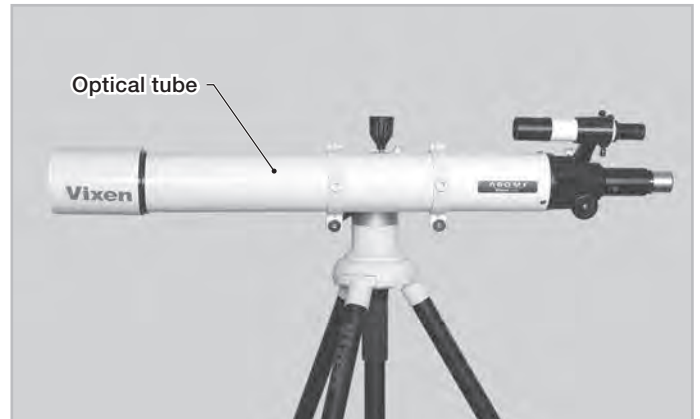

### ⚠ Caution:

Do not loosen the tube ring lock knobs too much in balancing. This could cause telescope tube to fall and lead to injury or damage to your equipment.

- 2 Tighten the tube ring lock knobs to hold the telescope tube. Swing the telescope tube up or down by holding the tip of the optical tube with hand to make sure that the telescope tube stops as you release your hand.

- 3 Repeat the above procedure until the telescope tube is balanced and it remains stationary. Tighten the tube ring lock knobs securely.



### Note:

It may be necessary to make a balance adjustment in combination with the dovetail slide bar if you use a short optical tube for the mount.

## APPLICATION

### Power Supply

- 1 Level the telescope tube as shown in the figure. Release the telescope tube to see if it keeps the position as it stands. Readjust the balance if the telescope tube starts turning as you release it.



- 2 Loosen the lock screw and safety screw on the mount head that hold the telescope's dovetail slide bar and slide the dovetail slide bar either forward or backward until the telescope tube remains stationary.

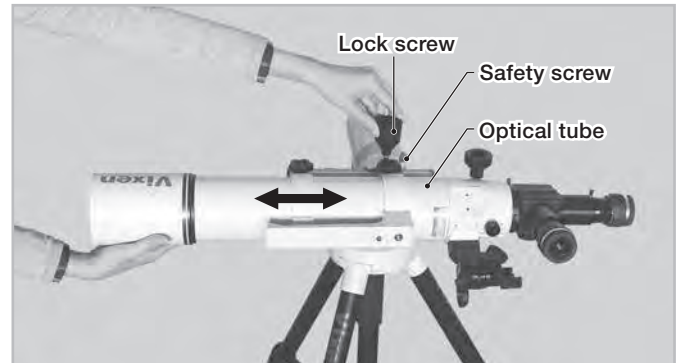

#### ⚠ Caution:

Do not loosen the lock screw and safety screw too much in balancing. This could cause telescope tube to fall and lead to injury or damage to your equipment.

- 3 Tighten the lock screw to hold the telescope tube. Swing the telescope tube up or down by holding the tip of the optical tube with hand to make sure that the telescope tube stops as you release your hand.
- 4 Repeat the above procedure until the telescope tube is balanced and it remains stationary. Tighten the lock screw and safety screw securely.

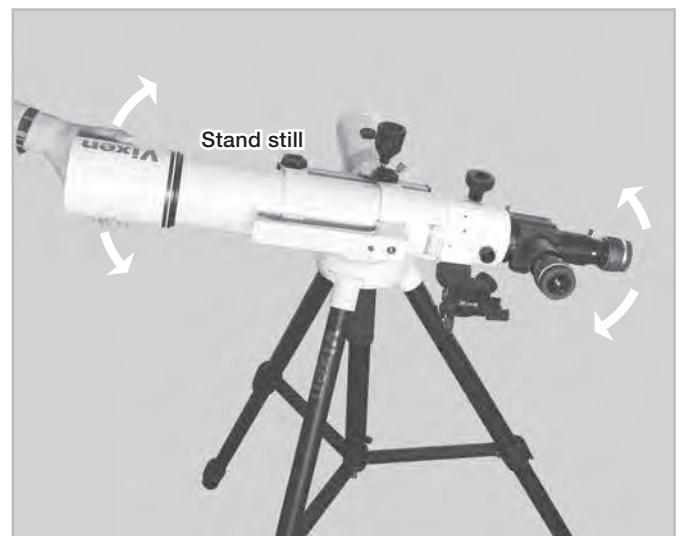

## BASIC OPERATION

First, you need to accustom yourself to the basic operation of the altazimuth mount.

### Moving the APZ Mount

- 1 The mount is designed to move and stop the rotational axes without a clamp system.

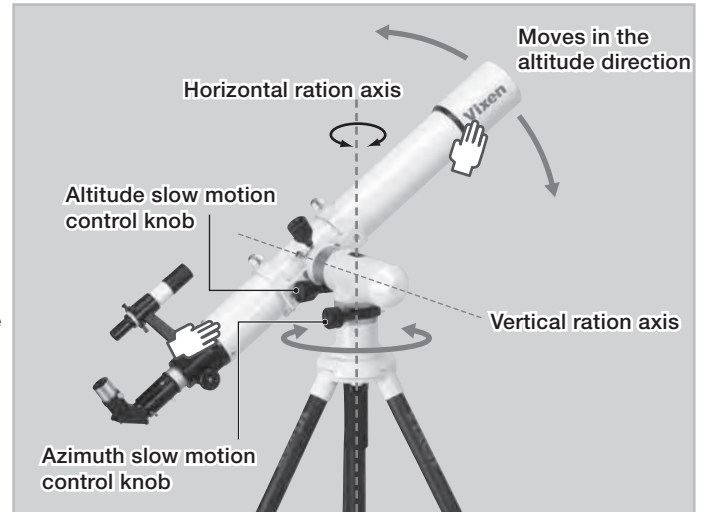

- 2 The tracking and slow motion control are moved manually with the slow motion control knobs.

## APPLICATION

### Changing Tension of the Friction Stop Motion

The tension of the friction stop motion can be adjusted in the altitude and azimuth directions as the need arises.

The position of each tension adjustment screw is shown in the figure.

Adjust the tension of the friction stop motion by loosening or tightening the tension adjustment screws with the supplied 4mm Allen wrench. Be sure to loosen the tension adjustment screw while holding the optical tube as it may quickly affect the balance.

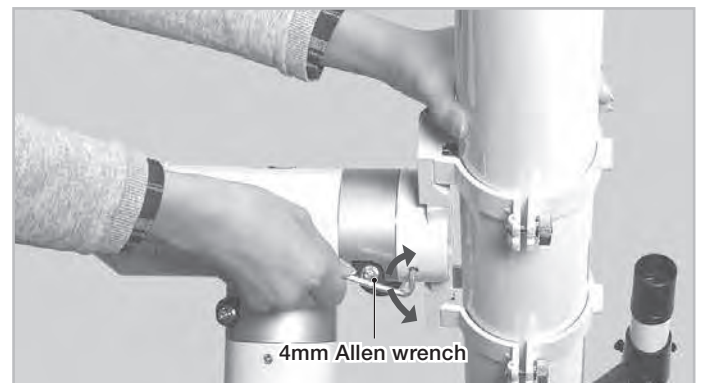
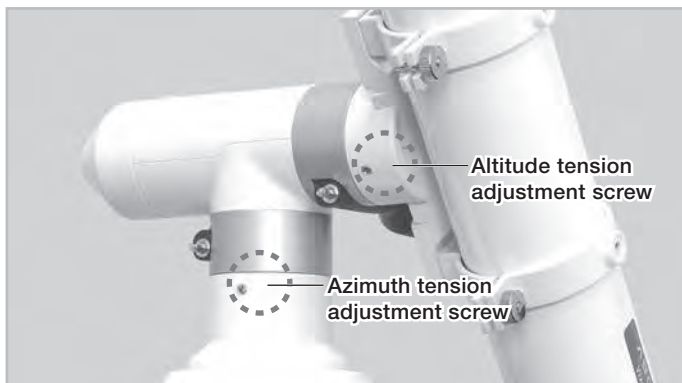

## APPLICATION

### Power Supply

The R.A motor module is available as an addition to the APZ mount. This includes the STAR BOOK ONE and is powered using AA-size batteries or a USB external battery.

If you want to move the mount electrically in the altitude and azimuth directions, both the R.A and DEC motor modules are required. The following are requirements if you use an external power source such as a USB external mobile battery for the APZ mount.

#### Power supply to the R.A motor module only:

The USB external power supply battery of 0.5 ampere and more is needed.

The USB Micro-B connector is needed.

#### Power supply to both the R.A and DEC motor modules:

The USB external power supply battery of 1.0 ampere and more is needed.

The USB Micro-B connector is needed.

In case of a shortage of the power supply, the DEC motor will stop along with a blinking message that „Y motor stop“.

Y motor  
stop

#### Note:

The USB external power supply battery in conformity to DCP (Dedicated Charging Port) of USB Battery Charging Specification, Rev 1.1 is required.

### Using AA-size Batteries

The AA-size alkaline batteries or Ni-MH or Ni-Cd rechargeable batteries of AA-size are recommended.

#### 1 Remove the battery compartment cover on the declination body.

Open up the cover of the window hole for the polar alignment scope on the declination body. Push down on the hook on the body and pull out the declinations body cover by pinching the hook and window hole with fingers.

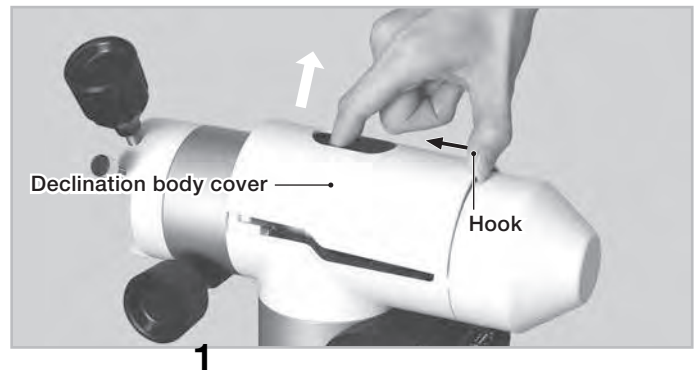
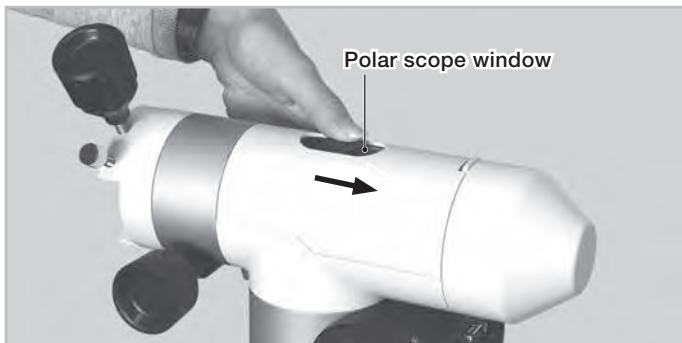

#### 2 Insert four AA batteries to the battery compartment inside the declination body, checking the polarity of the batteries.

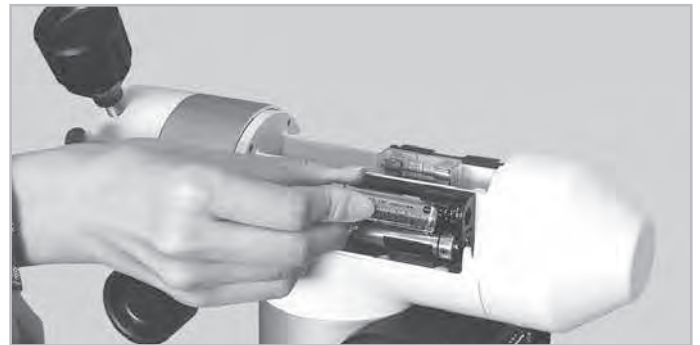

#### 3 Replace the battery compartment cover.

##### Note 1:

If the batteries are exhausted (its voltage power is dropped), the display on the STAR BOOK ONE begins blinking. If this happens, exchange the batteries for new ones (or fully recharged ones).

##### Note 2:

Use AA batteries of the same rating. Do not mix new batteries and old batteries. This could cause leakage of battery fluids.

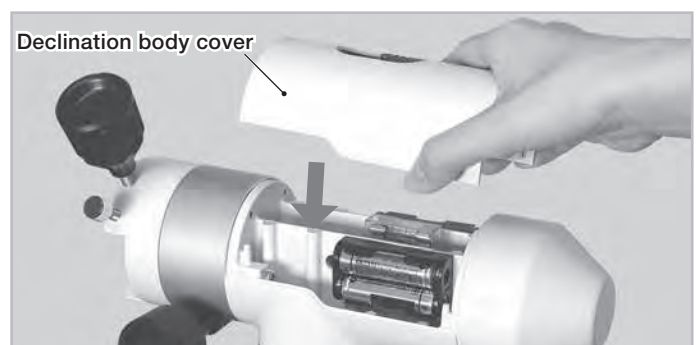

## APPLICATION

### Using a USB External Power Supply

A commercially available USB external battery with USB micro-B connector is needed.

Connect the USB external battery to the external power supply port of the R.A motor module with a USB micro-B connector cable as shown in the figure.



#### Note 1:

The USB external battery will take priority over the AA batteries if you turn on the power while the AA batteries remain in the battery compartment.

#### Note 2:

If the USB external battery is exhausted (its voltage over is dropped), the display on the STAR BOOK ONE begins blinking. If this happens, exchange the USB external battery for new ones (or fully recharged ones).

#### ⚠ Caution 1:

Be sure to turn off the power when you remove the USB external battery while the AA batteries remain in the battery compartment. Although this does not lead to damage, it may cause an operation error or initialize your settings on the STAR BOOK ONE.

#### ⚠ Caution 2:

When you unplug the power cable, be sure to hold the connector part and pull it straight. Unplugging by grabbing the cable part may cause a wire to snap.

#### ⚠ Caution 3:

Avoid pulling or bending a part of the power cable adjacent to the connectors. It may cause a wire to snap.

#### ⚠ Caution 4:

Do not use the power cable in a folded and tied condition. It may cause electrical shock or fire.

## APPLICATION

### Modules for the APZ Mount

The APZ mount is composed of various modules and parts. It can be easily rearranged or upgraded for your specific need.

### APZ Mount Composition Chart

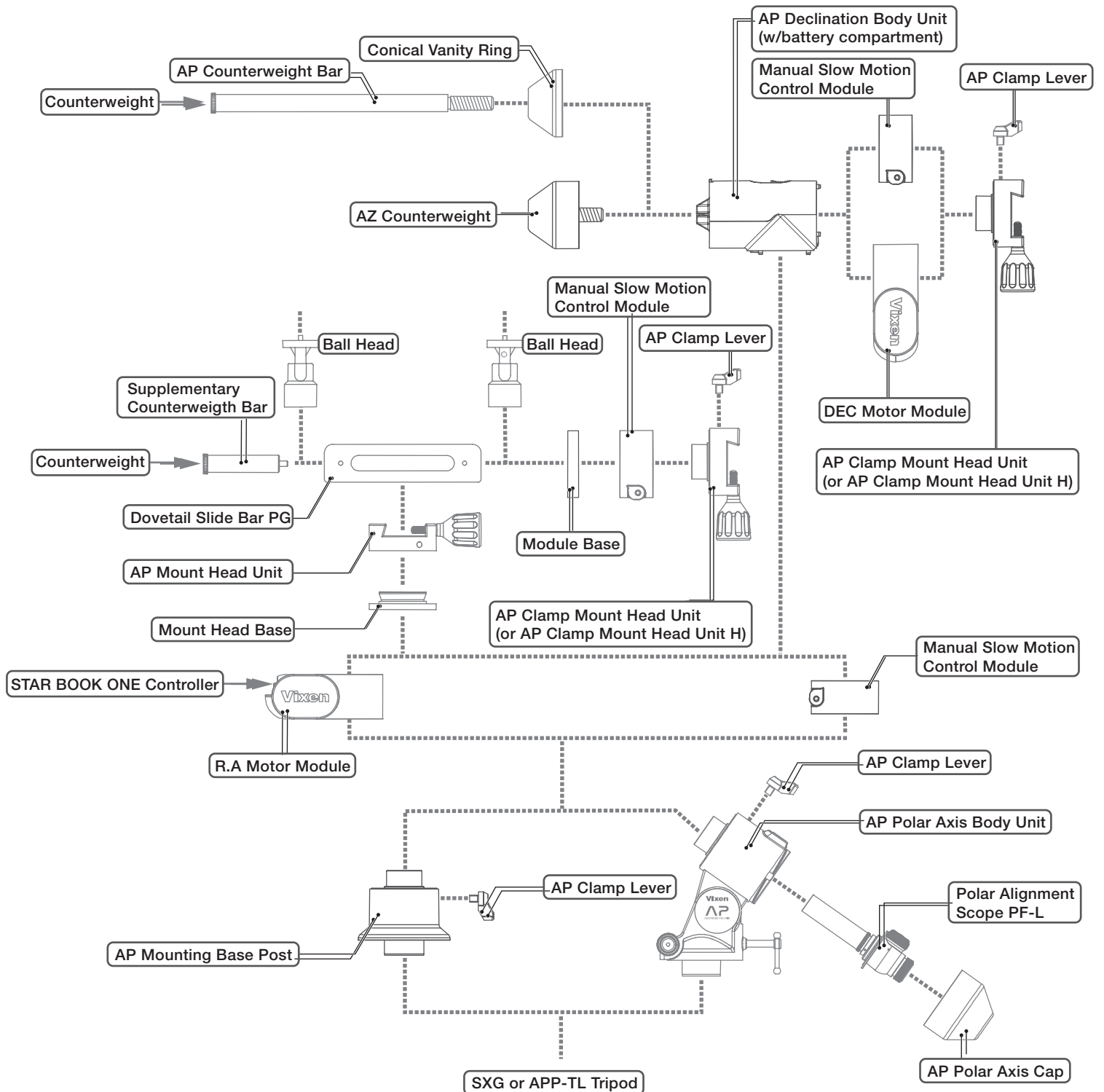

The polar axis body unit, R.A. motor modules are designed with internal joint electrical contacts. These modules are ready to connect to your power source when connected to each other.

The R.A. motor module is provided with the controller connecting port and external power supply port (USB Micro-B). The R.A. motor module is essential when you use the external power supply.

The AP declination body unit has a built-in battery compartment as a power source.



# APPLICATION

## Variations on the APZ Mount

### Example 1:

AP Mount with Manual Slow Motion Controls

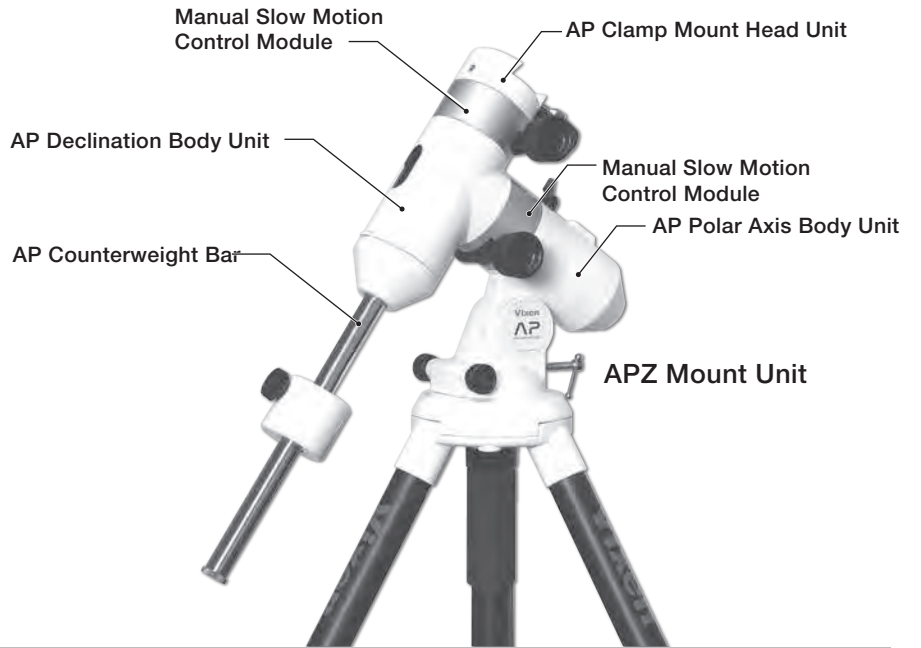
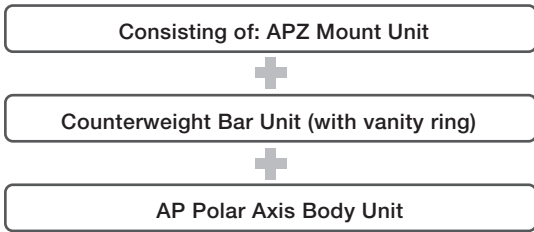

### Example 2:

Using APZ Mount for Time-lapse Photography

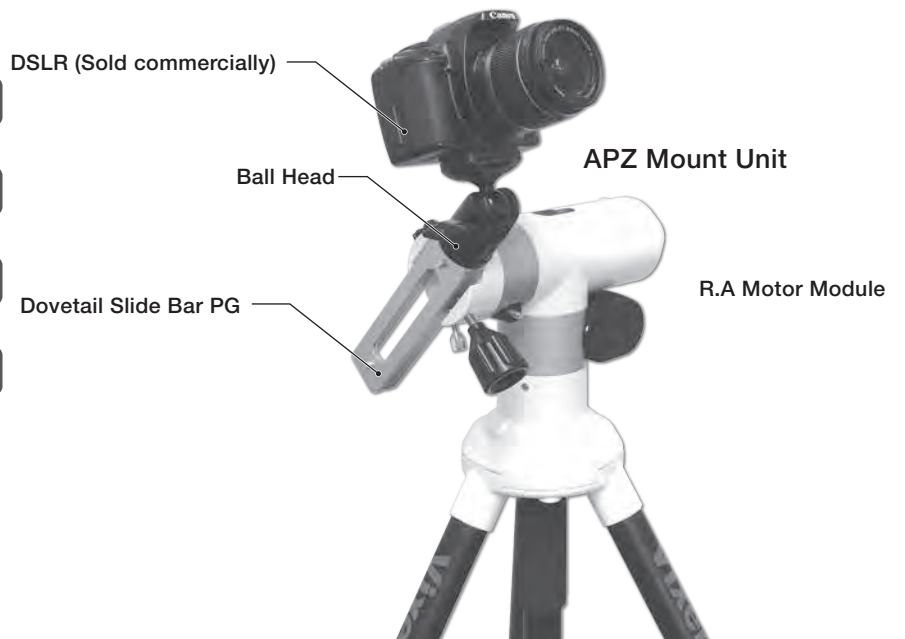
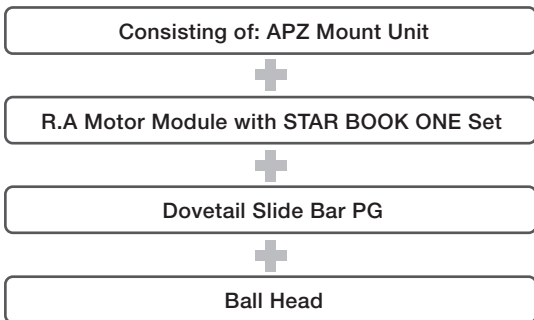

## APPLICATION

### How to Change the Modules

Remove the optical tube, counterweight bar and controller before changing modules. Take out the batteries from the battery compartment and disconnect the external power supply if it is used.

Example 1: Changing the APZ Altazimuth Mount into the AP Equatorial Mount (with manual slow motion controls)

Install the AP counterweight bar unit and AP polar axis body unit in the APZ Mount.

- 1 Remove the APZ counterweight.  
The APZ counterweight comes off if you turn it counter-clockwise. Take care not to drop the counterweight as it could seriously damage the equipment or lead to injury.

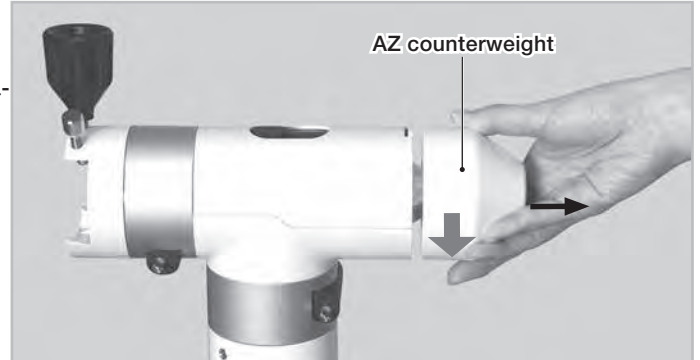

- 2 Take off the declination body cover.  
Open up the polar scope window on the declination body unit by sliding down the shutter. While pushing down on the hook on the edge of the declination body, pull out the declination body cover by pinching the hook and window hole with fingers.

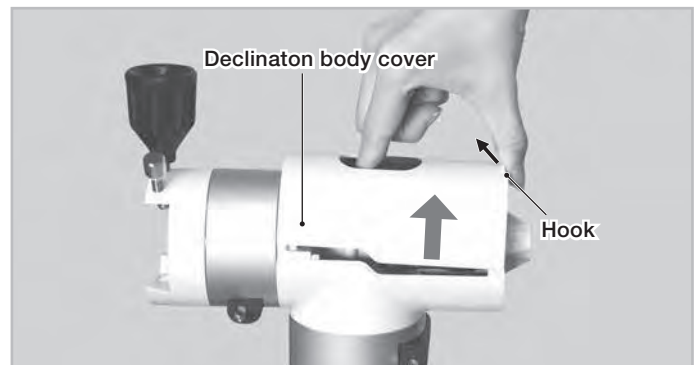
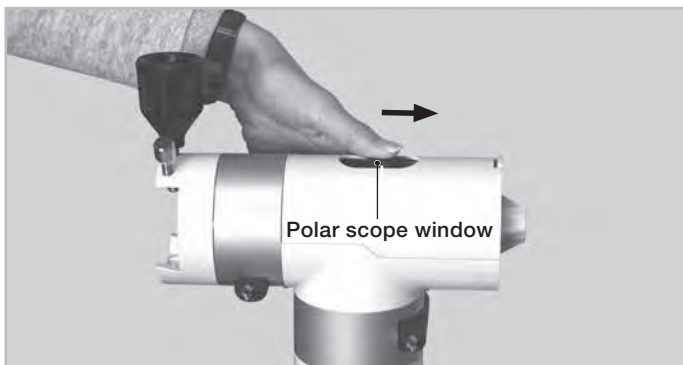

- 3 Loosen the two socket head cap screws on the declination body with the 4mm Allen wrench as shown in the figure. Remove the declination body assembly including the manual slow motion control module. Be sure to hold the declination body securely while loosening the screws.

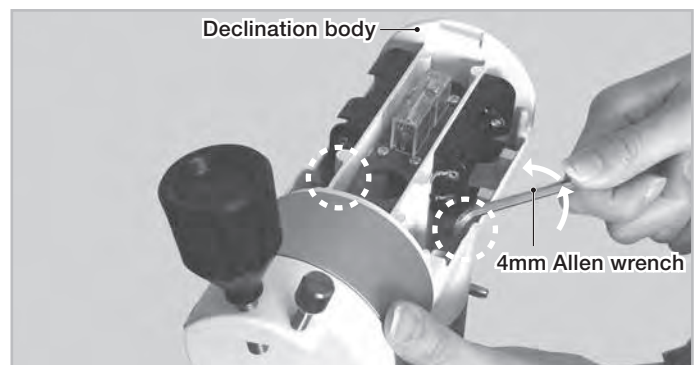

#### ⚠ Caution:

The internal joint electrical contact of the declination body is very delicate. Take care not to touch with fingers or other objects.



After removing the declination body

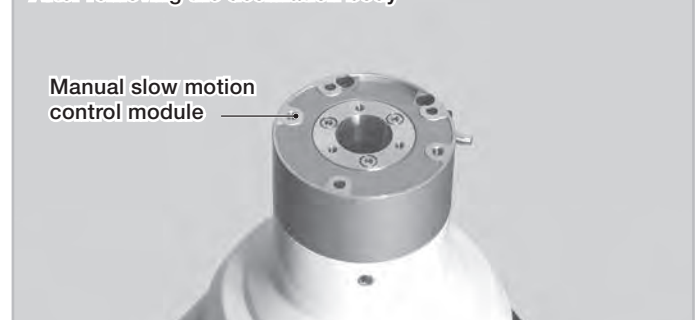

## APPLICATION

- 4** Loosen the three socket head cap screws on the manual slow motion control module with the 3mm Allen wrench. The manual slow motion control module comes off.

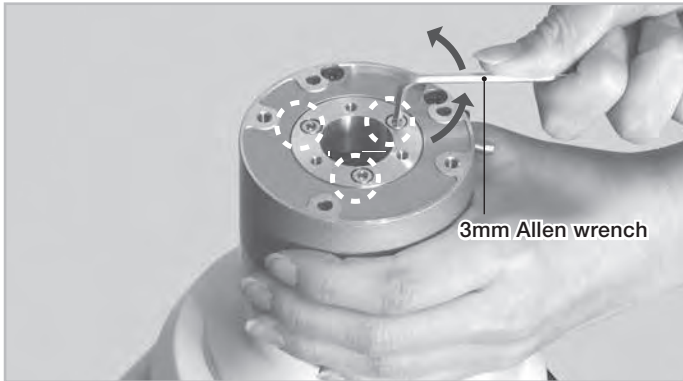

- 5** Remove the AP mounting base post from the tripod head. Loosen the lock screw of the leg brace and raise the leg brace so that you can turn the center column. The AP mounting base post comes off as you turn the center column clockwise. Hold the AP mounting base post in one hand to prevent it from turning together with the center column.

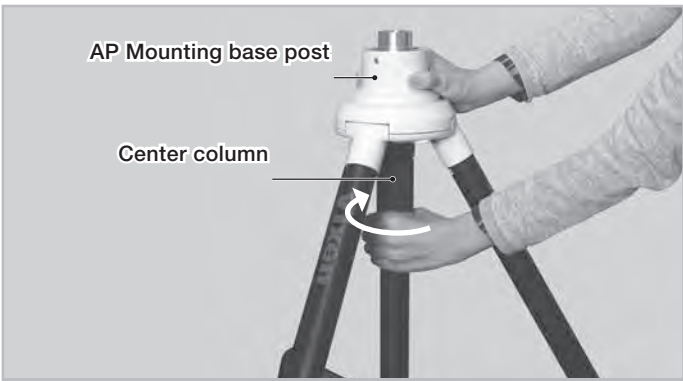
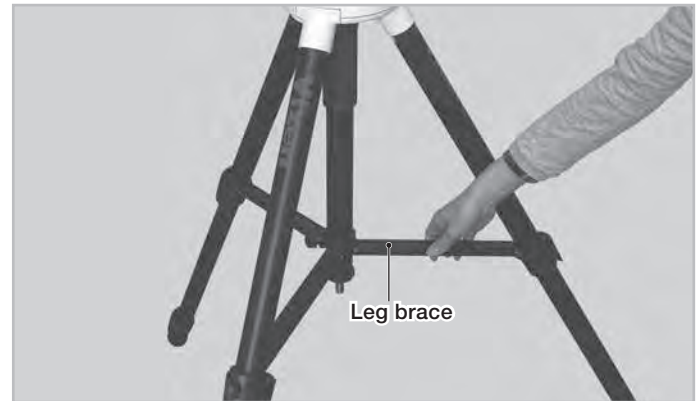
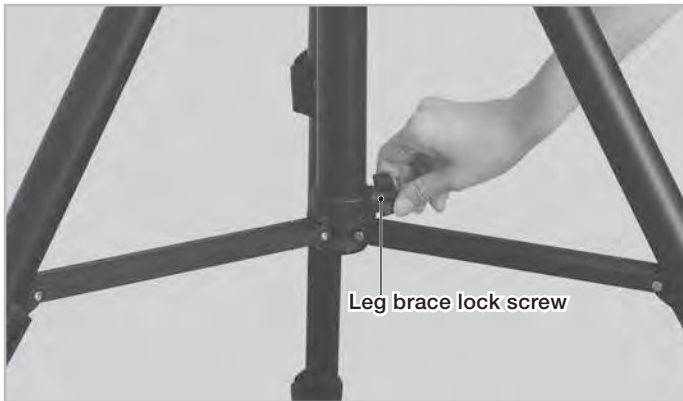

- 6** Attach the metal post on the tripod head. The metal post is underneath the center column. Be sure to screw down the metal post completely using a standard screwdriver.

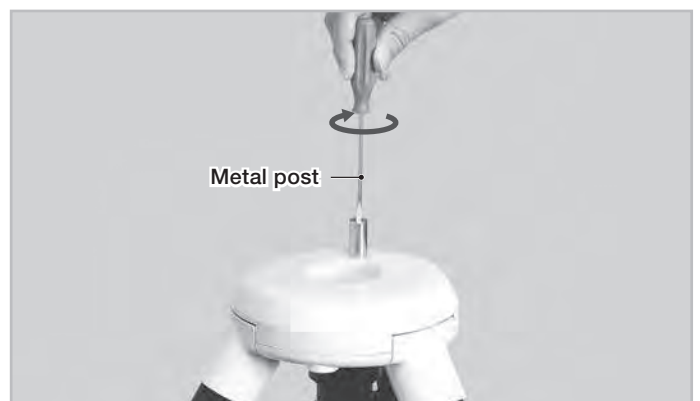
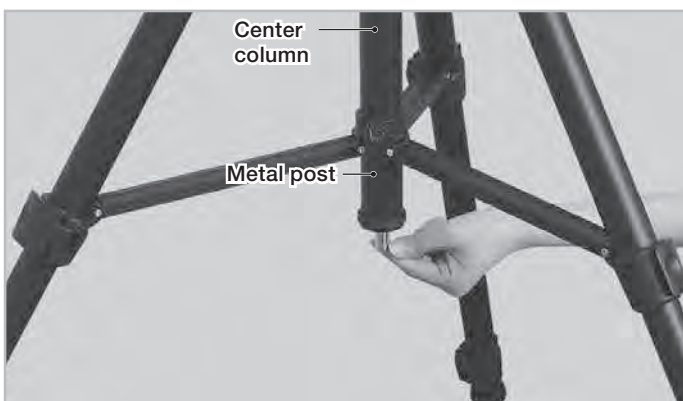

## APPLICATION

- 7** Place the AP polar axis unit on the tripod head.  
Loosen the azimuth adjustment screw in advance by turning the azimuth adjustment knobs as shown in the figure so that a space is opened for the metal post between the screws.

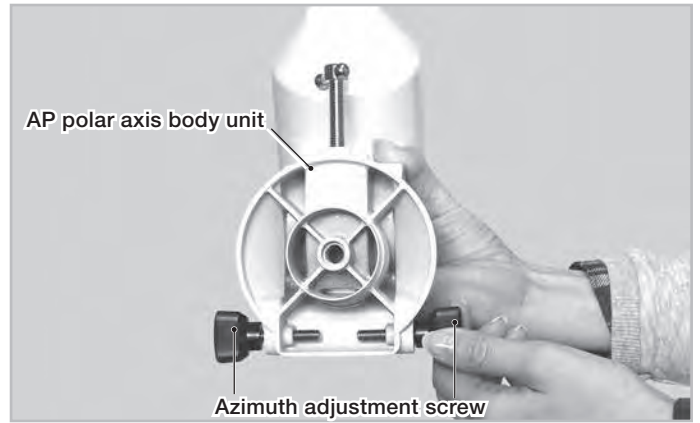

- 8** Position the mount base of the AP polar axis body unit so that the two azimuth adjustment screws come above the metal post. Place the mount base so that the center projection on the bottom of the mount base fits the center hollow on the tripod head.

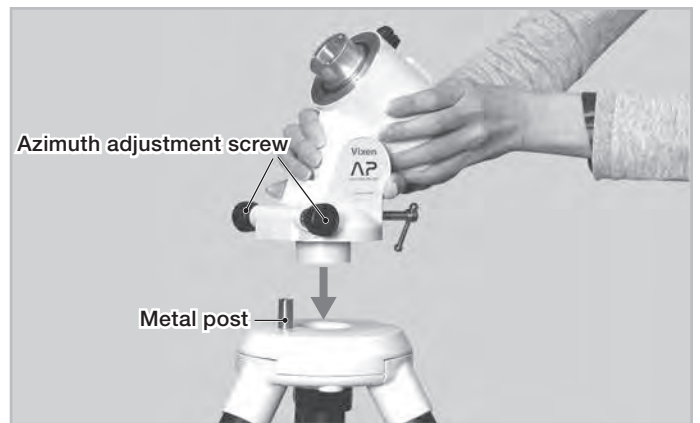

- 9** Tighten the azimuth adjustment knobs on the mount base so that the two knobs are equally tightened.

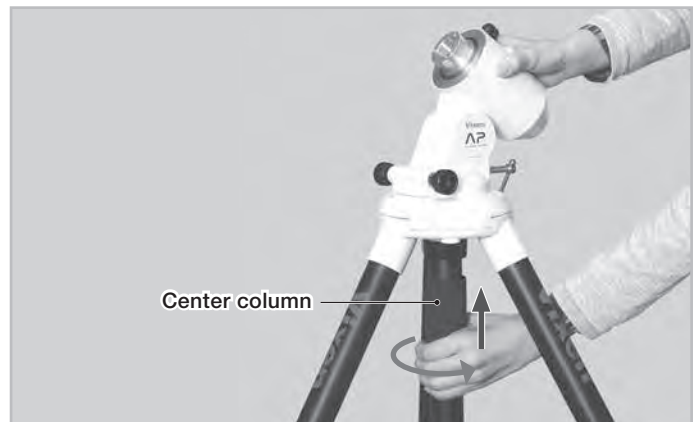

- 10** Tighten the azimuth adjustment knobs on the mount base so that the two knobs are equally tightened.

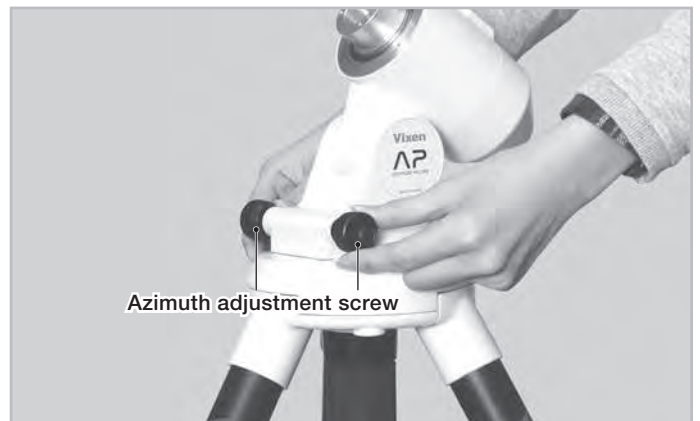

## APPLICATION

- 11** Attach the manual slow motion control module onto the AP polar axis body unit so that the center hollow (large side) of the module fits snugly onto the center protruded portion of the AP polar axis body unit.

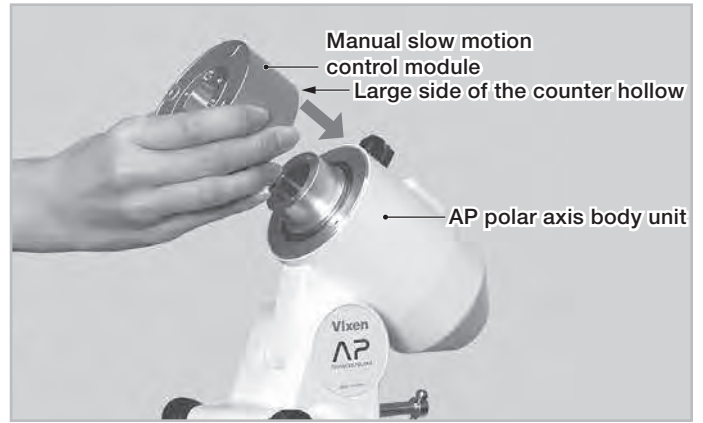

- 12** Rotate the manual slow motion control module so that the screw holes (larger holes with no thread) are aligned in tandem. Replace the three socket head cap screws in place.

Tighten the screws with the 3mm Allen wrench securely.

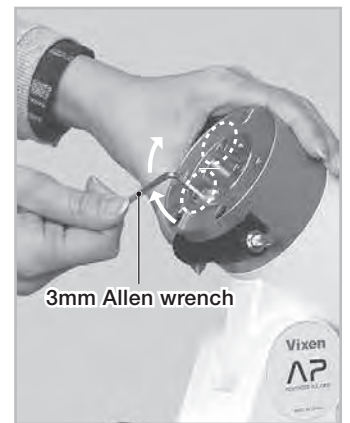

- 13** Attach the declination body assembly onto the AP polar axis body unit so that the electrical contact on the declination body fits into the sunken portion on the manual slow motion.

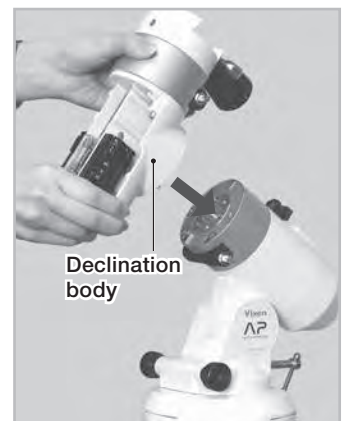
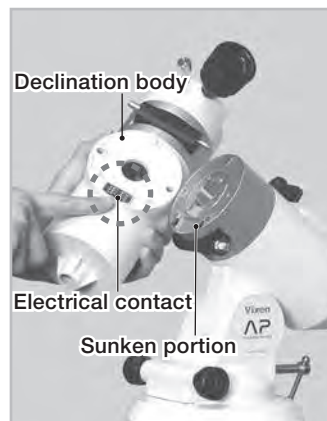

- 14** With holding the declination body in one hand, replace the two socket head cap screws that were removed in step 3 above.

Tighten the screws with the 4mm Allen wrench securely.

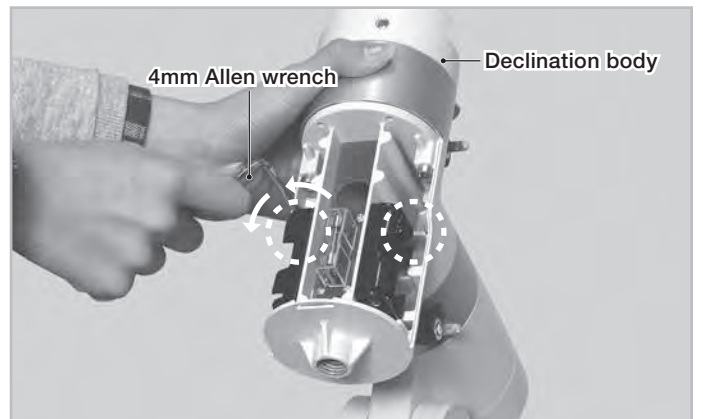

## APPLICATION

- 15** Replace the declination body cover with attention to the direction of the hook on the corner.

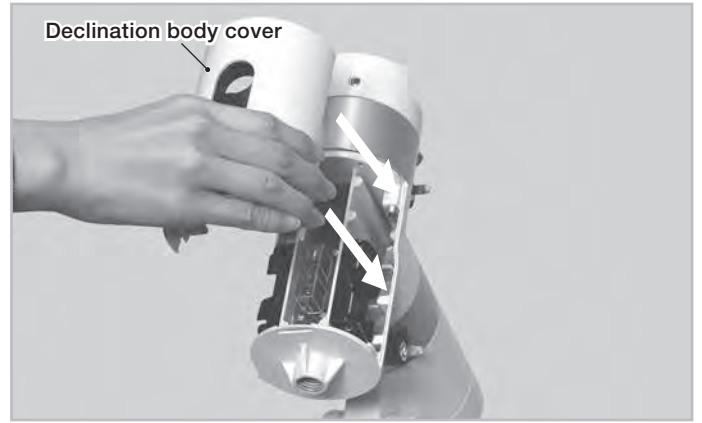

- 16** Screw the threaded end of the counterweight bar into the threaded hole on the conical vanity ring.

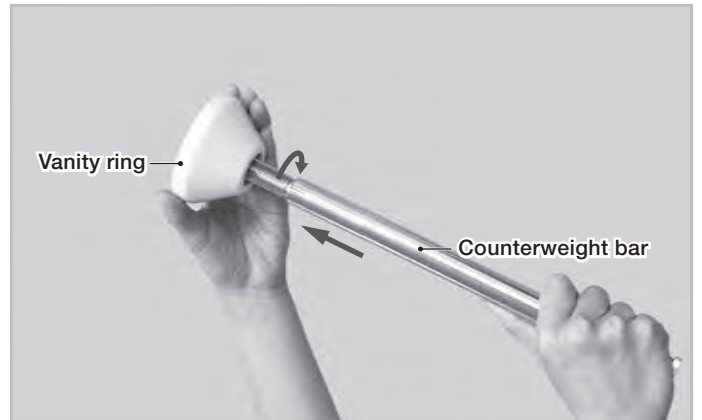

- 17** Screw the threaded end of the counterweight bar into the declination body.

Attach the declination body fully and securely tighten up the vanity ring.

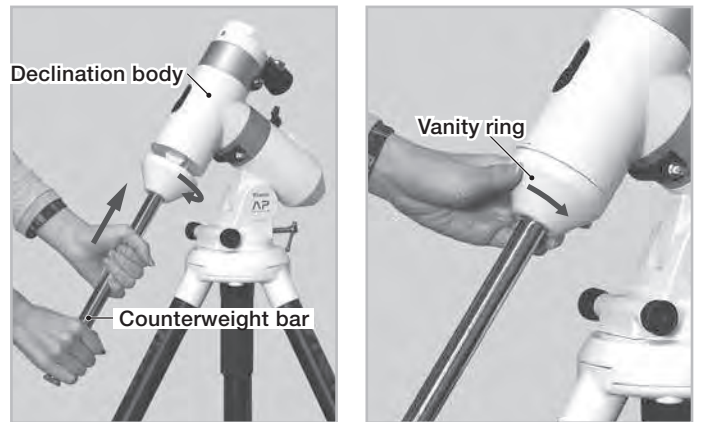

- 18** Remove the safety screw on the end of the counterweight bar.

Changing the AP equatorial mount completed.



## APPLICATION

- 19** Make sure that the counterweight bar is at the lowest position and attach the counterweight.

Loosen the lock knob on the counterweight and put through the counterweight. At this stage the counterweight should be close to the upper end of the counterweight bar to bring the center of balance near to the mount.

Tighten the lock knob on the counterweight securely.

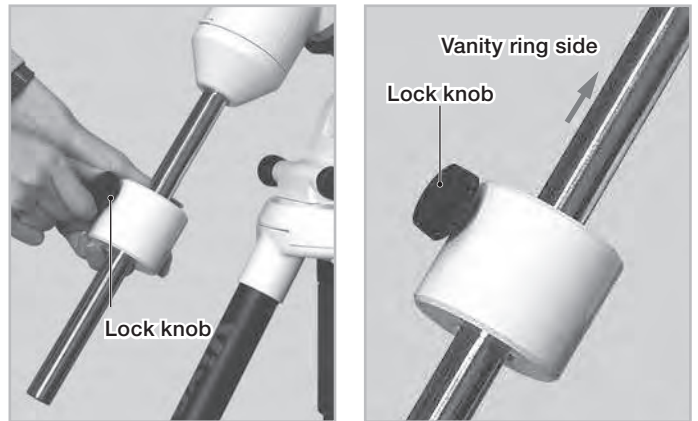

- 20** Replace the safety screw on the end of the counterweight bar and tighten it.



- 21** Changing the AP equatorial mount completed.



## APPLICATION

### Example 1: Changing the APZ Altazimuth Mount into the AP Equatorial Mount (with manual slow motion controls)

Replace the manual slow motion control module on the APZ mount for the R.A. notr module.

#### 1 Remove the APZ counterweight.

The APZ counterweight comes off if you turn it counter-clockwise. Take care not to drop the counterweight as it could seriously damage the equipment or lead to injury.

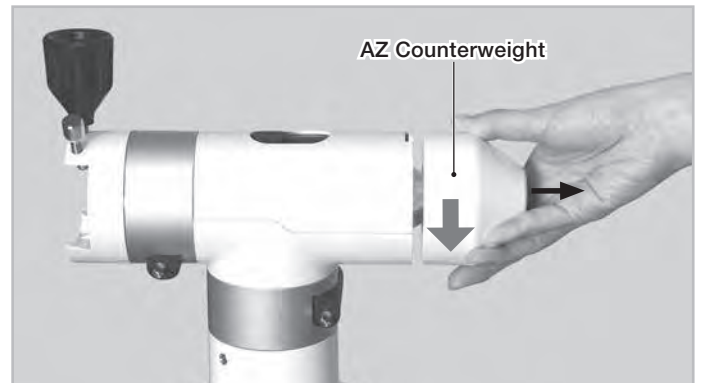

#### 2 Take off the declination body cover.

Open up the polar scope window on the declination body by sliding down the shutter. While pushing down on the hook on the edge of declination body, pull out the declination body cover by pinching the hook and window hole with fingers.

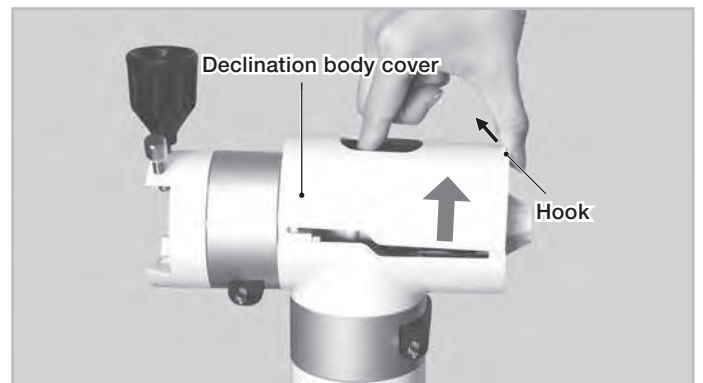
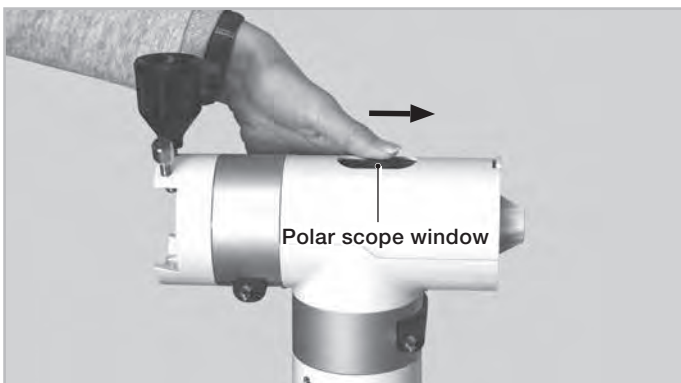

#### 3 Loosen the two socket head cap screws on the declination body with the 4mm Allen wrench as shown in the figure. Remove the declination body assembly including the manual slow motion control module. Be sure to hold the declination body securely while loosening the screws.

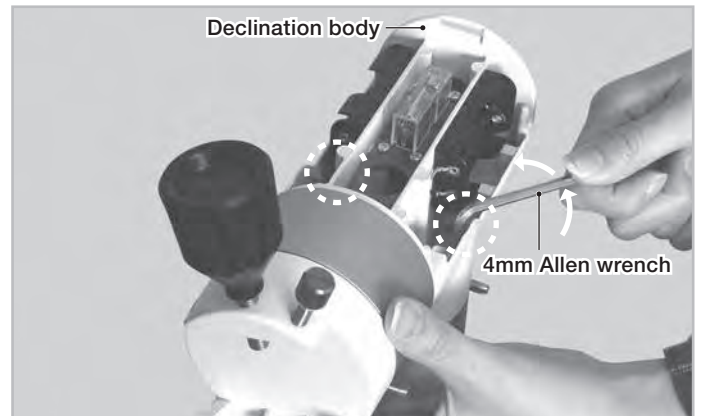

#### ⚠ Caution:

The internal joint electrical contact of the declination body is very delicate. Take care not to touch with fingers or other objects.



After removing the declination body





## APPLICATION

- 4** Loosen the three socket head cap screws on the manual slow motion control module with the 3mm Allen wrench. The manual slow motion control module comes off.

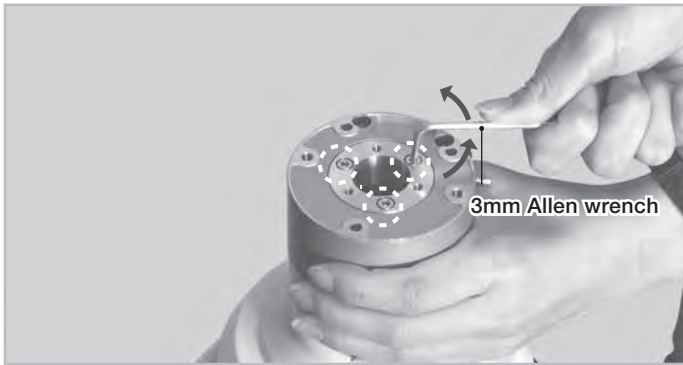

- 5** Attach the R.A motor module onto the AP mounting base post so that the electrical contact faces to the outside as shown in the figure.

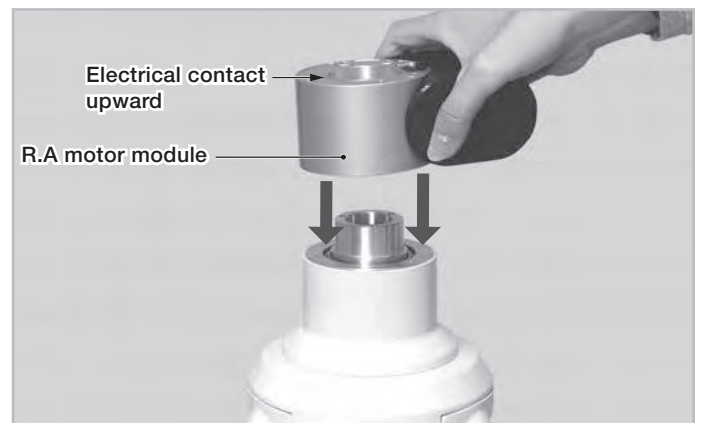
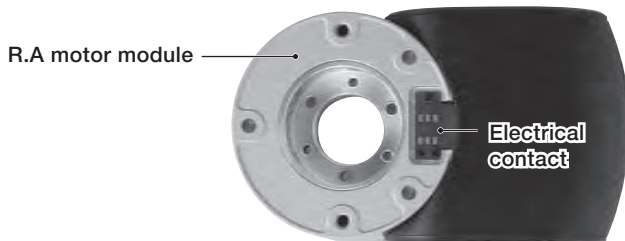

- 6** Rotate the R.A motor module to change the orientation so that the screw holes (larger holes with no thread) are aligned in tandem. Replace the three socket head cap screws in place and tighten the screws securely with the 3mm Allen wrench.

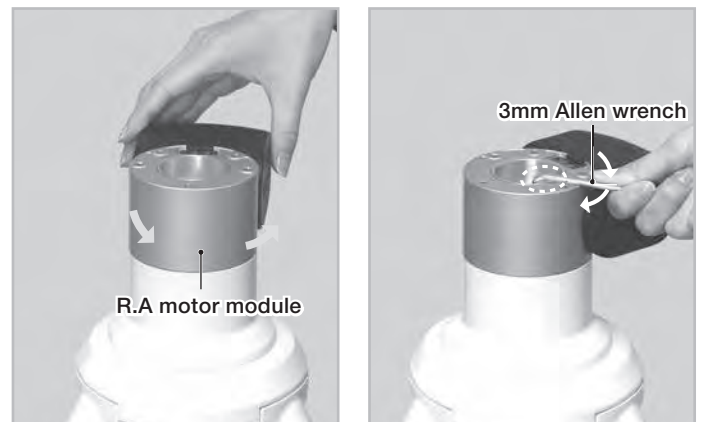

- 7** Attach the declination body onto the R.A motor module assembly so that the electrical contact on the declination body fits the counterpart on the R.A motor module.

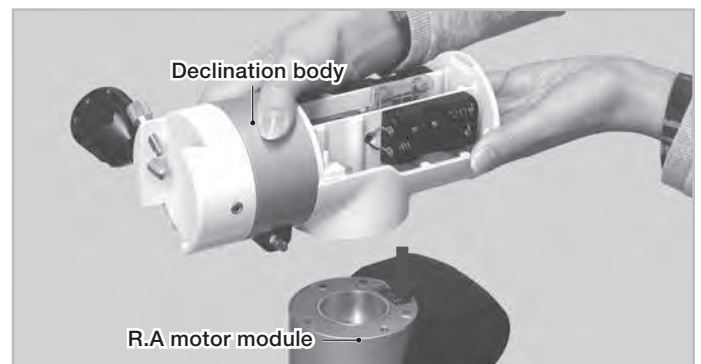
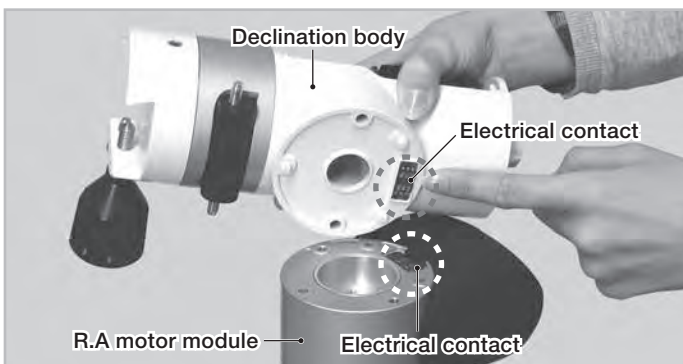

## APPLICATION

- 8 With holding the declination body in one hand, replace the two socket head cap screws that were removed in step 3 above. Install the batteries, if necessary. Tighten the screws securely with the 4mm Allen wrench.

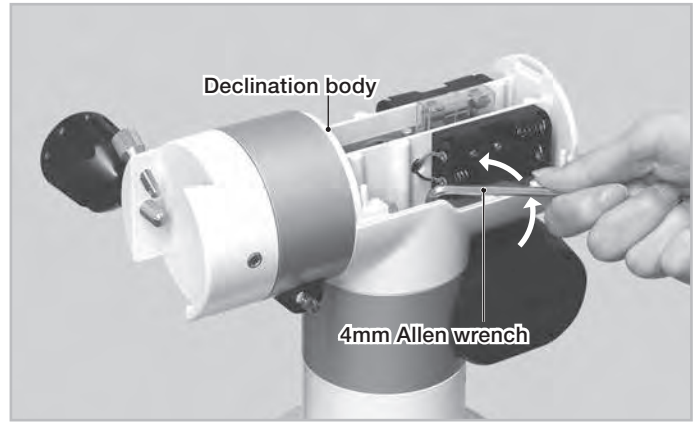

- 9 Replace the declination body cover with attention to the direction of the hook on the cover.

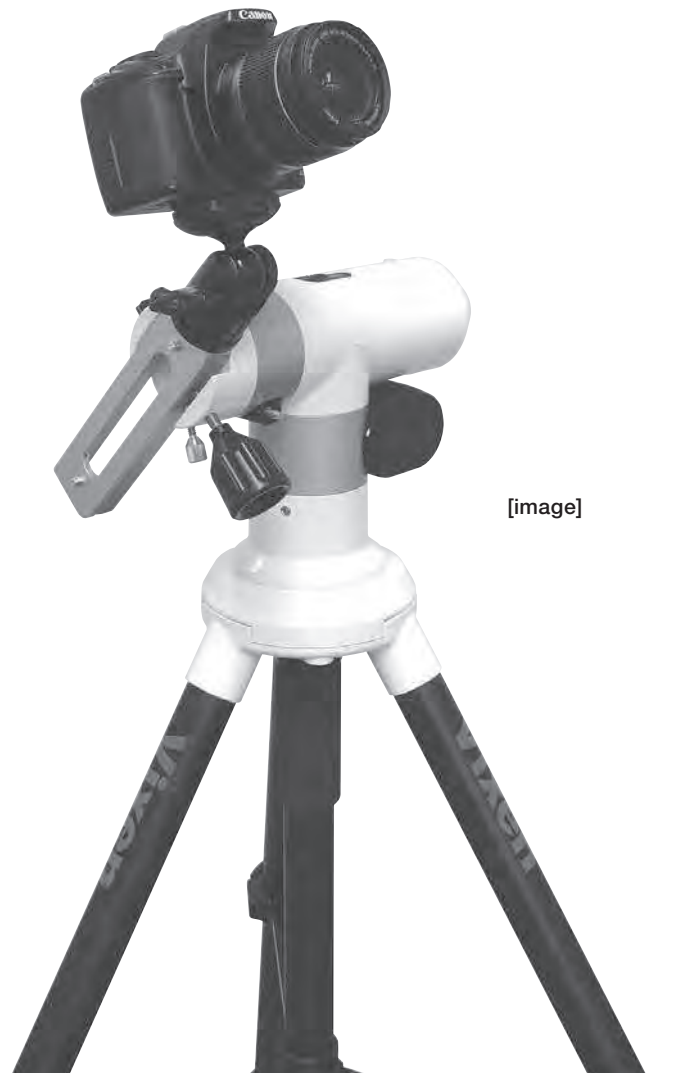
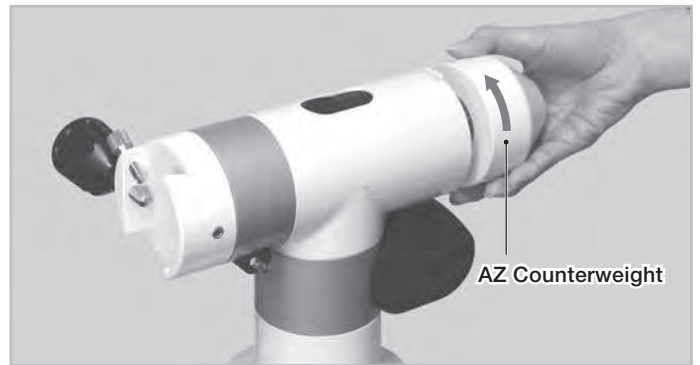

## APPLICATION

### About a Fuse Box

In the AP mount the electrical circuit board is protected by a fuse. It is a rare case that a fuse it cut off in general use of the mount. If this happens, you will need to replace the fuse with a fresh one.

Specifications:  
125 V 1A Class-B (PSE standard)  
6mm dia. x 30mm

### Replacing the Fuse

#### 1 Remove the declination body cover.

Open up the polar scope window on the declination body by sliding down the shutter. While pushing down on the hook on the bottom of the declination body, pull out the declination body cover by pinching the hook and window hole with fingers.

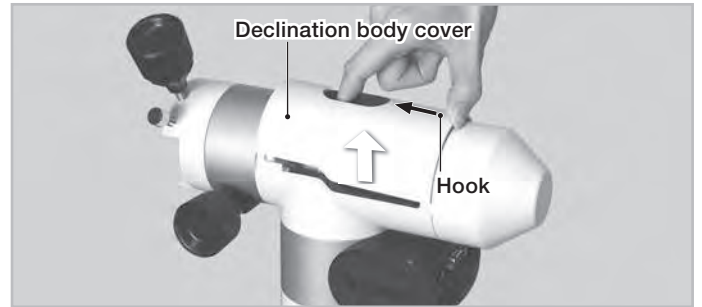
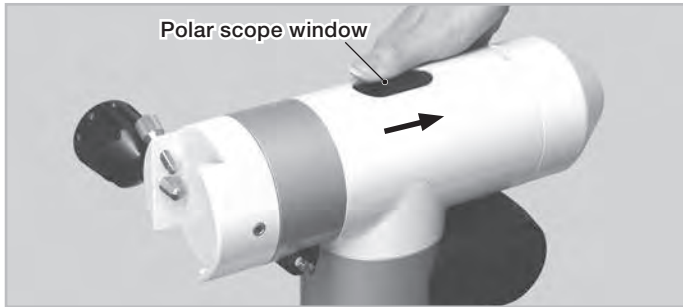

#### 2 Remove the batteries from the declination body. Do not disassemble the mount without removing the batteries. This may cause damage.

#### 3 Remove the cover of the fuse box.

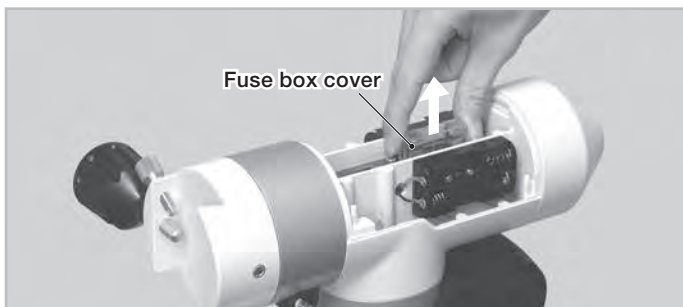

#### 4 Pull out fuse.

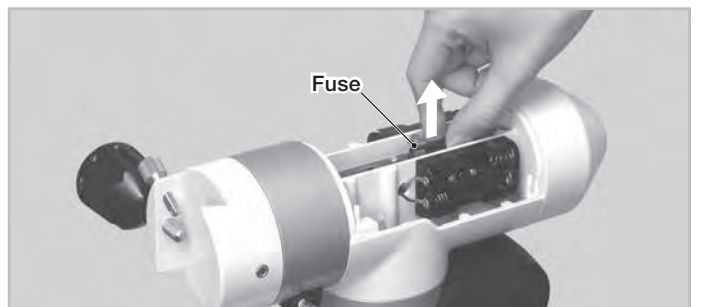

#### 5 Push a new fuse into the fuse box to set.

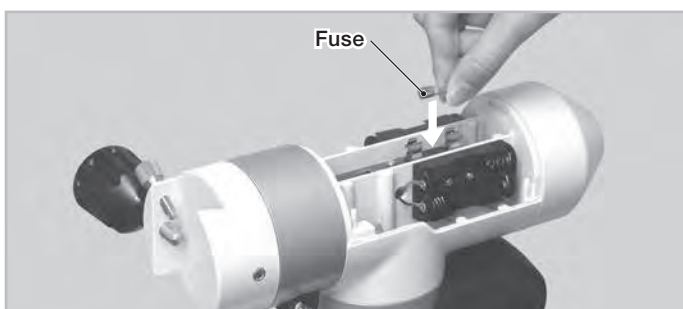

#### 6 Put the cover on the fuse box and install the batteries, if necessary.

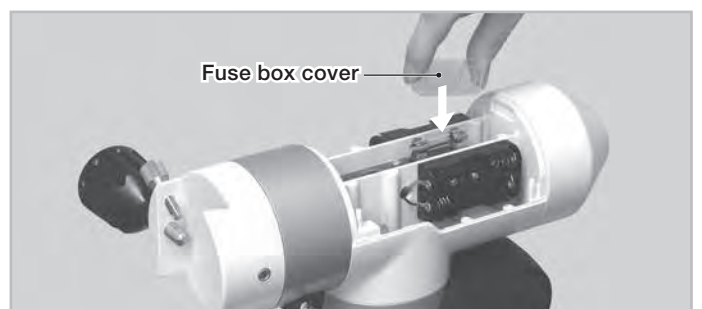

#### 7 Replace the declination body cover noting the direction of the hook on the cover.

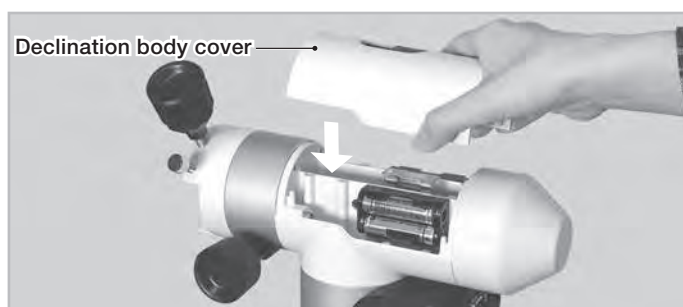

## SPECIFICATIONS

### Mount Specifications

Mount	APZ Altazimuth mount
Slow Motion Control	Altitude: Wheel and worm gears full circle micro movement Azimuth: Wheel and worm gears full circle micro movement
Quick Slewing Motion	Friction stop motion (adjustable)
Wheel Gear	Altitude: 73.5mm in diameter, 144-tooth wheel gear Azimuth: 58.4mm in diameter, 144-tooth wheel gear
Worm Gear	Altitude: 11.0mm in diameter, Brass Azimuth: 9.8mm in diameter, Brass
Horizontal Axis	59mm in diameter, Aluminium alloy, with friction stop mechanism
Vertical Axis	59mm in diameter, Aluminium alloy, with friction stop mechanism
Number of Bearings	6 pieces
Maximum Loading Weight	8kg (6 kg if the DEG motor modules are used) (18 lbs) (13 lbs)
Dimensions	178 x 258 x 104mm
Weight	3.8kg (incl. APZ counterweight) (8.3 lbs)
Counterweight	APZ counterweight 1.65kg (3.6 lbs)
Optional Accessories	R.A Motor module with STAR BOOK ONE Set, DEC motor module, APP-TL130 tripod, Dovetail slide bar

The specifications are subject to change without notice.

### APZ Mount Dimensions

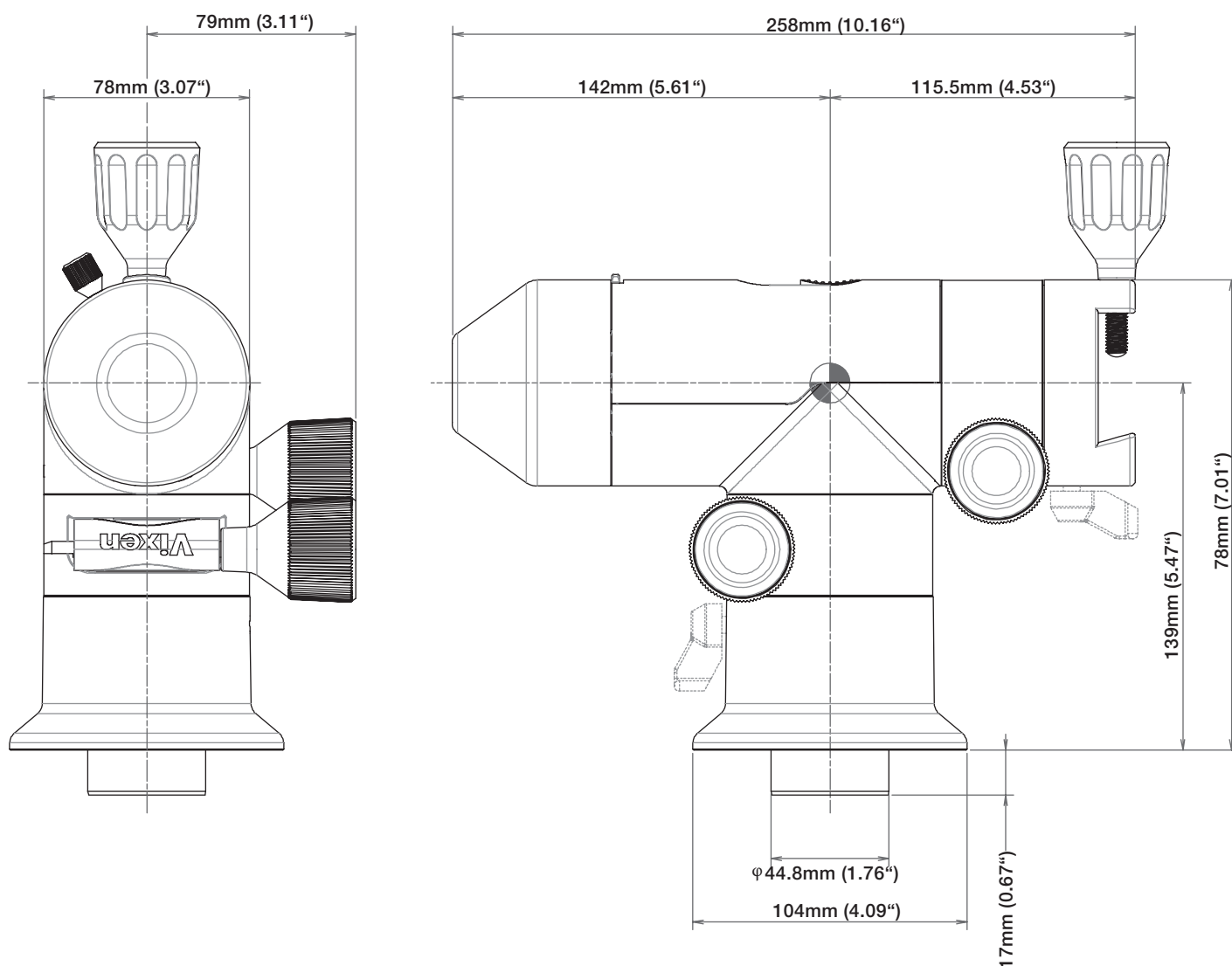

## SPECIFICATIONS

### Manual Slow Motion Control Module Dimensions

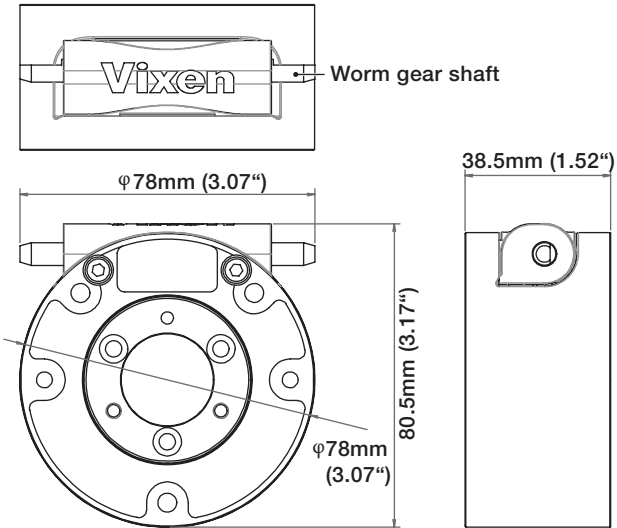

### Manual Slow Motion Control Module Dimensions

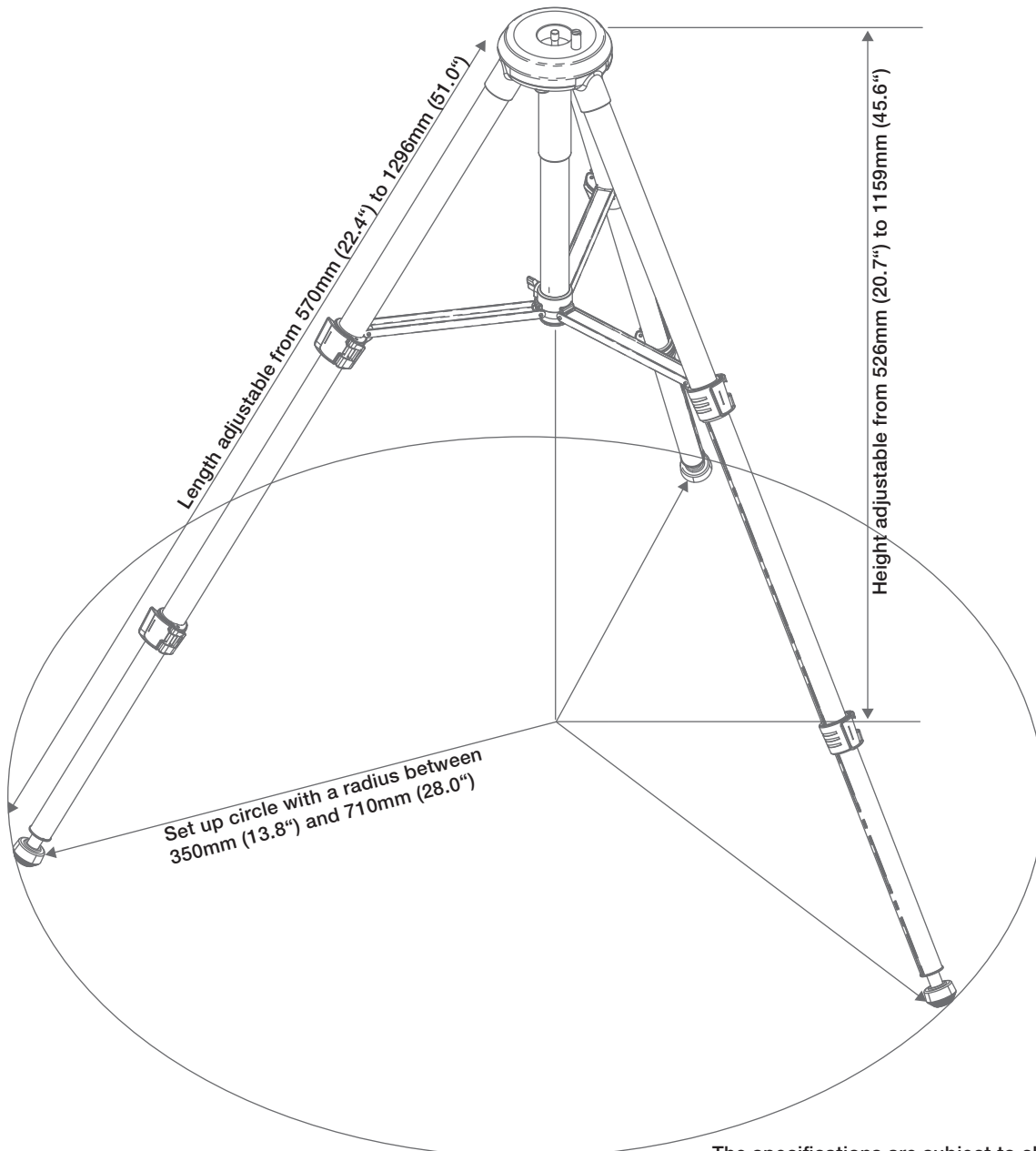

The specifications are subject to change without notice.





# Vixen®

Errors and technical changes reserved. / Manual\_X000056\_APZ-Alt-Az-Mount\_en\_VIXEN

---

# Vixen®

European Distributor:  
Bresser GmbH  
Gutenbergstr. 2, 46414 Rhede  
Germany

Service for Great Britain & Ireland:  
Telephone: +44 1342 837 098  
E-Mail : [service@bresseruk.com](mailto:service@bresseruk.com)  
[www.bresseruk.com](http://www.bresseruk.com)